

SHOP MANUAL ■ PROPELLER SHAFT □
REAR AXLE AND SUSPENSION

■ GIULIA 1300 ■ GIULIA 1300 ti ■ GIULIA TI SUPER ■ GIULIA SPRINT GT ■ GIULIA GTC ■
■ GIULIA TI ■ GIULIA SUPER ■ GIULIA SPRINT GT VELOCE ■ SPIDER 1600 ■

**ALFA
ROMEO**



This Manual, supplied to all authorised ALFA ROMEO Repair Shops contains instructions for the servicing, overhaul and re-conditioning of the following chassis components: propeller shaft, suspensions and rear axle, steering system of GIULIA Models.

The operations are amply illustrated so that the detail and unit concerned can be quickly identified and the tools to be used and the correct method of operation can be seen.

Only genuine ALFA ROMEO spares should be used if any assemblies or parts have to be replaced; only in this way can complete interchangeability and fully satisfactory performance be guaranteed.

It is also recommended that, for all overhaul and reconditioning works, the suitable special tools be used.

This Manual should be kept continuously up-to-date by the addition of new information and instructions issued at intervals by the Technical Service Division in the regular « Information Sheets » and « Modification Instructions » which should be copied on to the blank pages at the end of the handbook.

**ALFA
ROMEO**

**Direzione
Assistenza**



CONTENTS

3 Servicing instructions

PROPELLER SHAFT

- 6 Cutaway view
- 7 Removal from car - Disassembly
- 8 Inspection and checking
- 9 Reassembly
- 10 Reassembly - Reinstallation

REAR AXLE AND SUSPENSION

Rear axle

- 12 -General
- 13 Cutaway view
- 14 In-car repairs
- 17 Removal
- 18 Disassembly on bench
- 19 Inspection and checking
- 20 Reassembly on bench
- 27 Reinstallation

Rear suspension

- 28 Cutaway view
- 30 Pads & rebound straps - Shock absorbers
- 32 Reaction trunnion
- 33 Suspension springs
- 34 Radius rods

SERVICING INSTRUCTIONS

When disassembling and reassembling always use the correct wrenches, extractors and tools (standard and special) to avoid damage to parts.

To loosen close-fitting steel parts lightly tap with a copper or aluminum mallet; for light alloy parts (covers, housings, etc.) use a wooden or plastic mallet.

When disassembling check that specially coupled parts are stamped with the correct number or reference mark; any original parts (previously replaced) found unmarked should be so stamped.

Components of different assemblies should be kept separate and nuts should be loosely screwed onto their original studs or bolts.

Before washing parts, brush or wipe off the thickest grime (to avoid soiling the solvent in the washing tank), then wash with paraffin or hot water and soda and remove any remaining dirt with compressed air; dry all parts immediately after washing so that they do not rust.

Deformed parts must be trued with the use of a hydraulic press or some other suitable means of applying pressure; hammering reduces mechanical strength and should be strictly avoided.

After parts have been ground or honed, wash them thoroughly and blow the parts with compressed air in order to remove all traces of emery powder.

When reassembling, clean components (particularly after regrinding) with compressed air or a clean dry brush.

When reassembling lubricate all mechanical parts properly (except carbon bushings) to prevent seizing and scoring when the engine is first run.

Use a brush and absolutely clean oil to apply a film of oil to all parts which have to be lubricated on reassembly; the brush, the oil and its container, should be kept completely free from dust and should be used for the above purpose only.

With adhesive paper or clean rags mask out those parts of the engine remained uncovered after disassembling to prevent dust or foreign matter from entering them.

When reassembling, renew all gaskets, oil sealing rings, spring washers, tabwashers, safety plates, locknuts and any components not in perfect condition.

Use always genuine ALFA ROMEO spares.

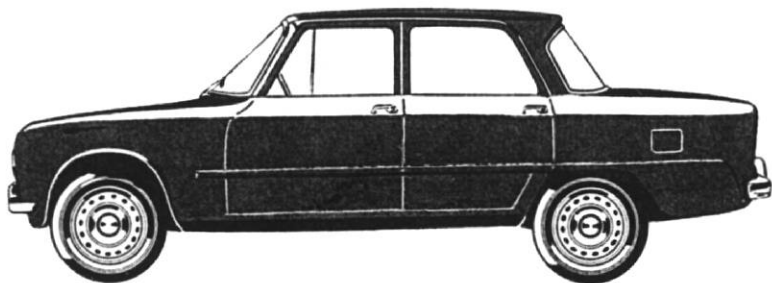

GIULIA 1300
GIULIA 1300 ti

GIULIA TI
GIULIA TI SUPER
GIULIA SUPER

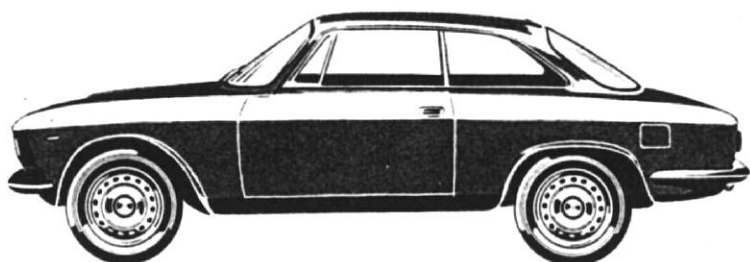

GIULIA SPRINT GT
GIULIA SPRINT GT VELOCE

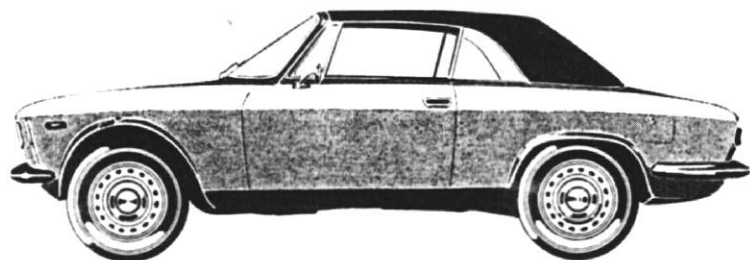

GIULIA GTC

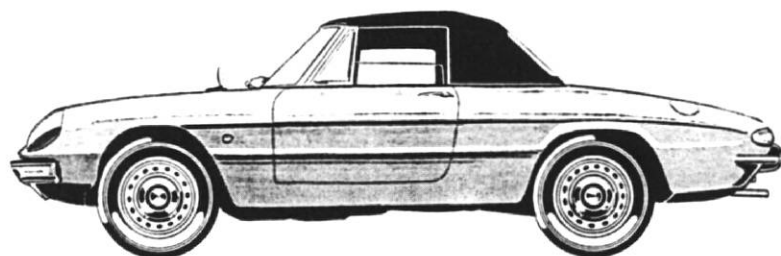

SPIDER 1600

PROPELLER SHAFT

PROPELLER SHAFT

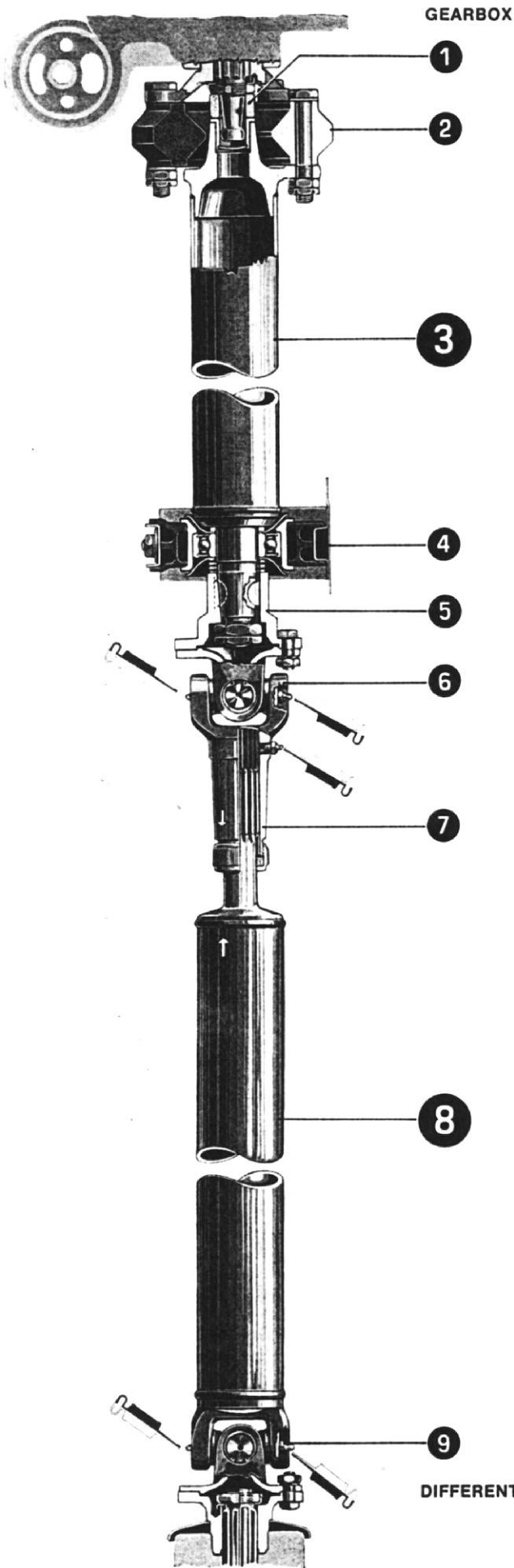

- 1 Grease seal
- 2 Flexible coupling
- 3 Shaft front section
- 4 Intermediate support, with ball bearing, elastically attached to body
- 5 Front shaft yoke
- 6 Universal joint, on needle bearings
- 7 Sliding yoke
- 8 Shaft rear section
- 9 Universal joint, on needle bearings



REMOVAL FROM CAR - DISASSEMBLY

- Remove:
 - the center cross-member 1;
 - hold the coupling securely with tool 3 (A.2.0124) and remove the bolts 2 fastening the flexible coupling to gear-box output shaft yoke;
 - loosen nuts 4 attaching intermediate support plate to body;
 - Remove bolts 5 fastening the propeller shaft yoke to differential input shaft yoke; before removing, countermark the parts for a proper reassembly as shown *.
- Take the propeller shaft away as a unit.

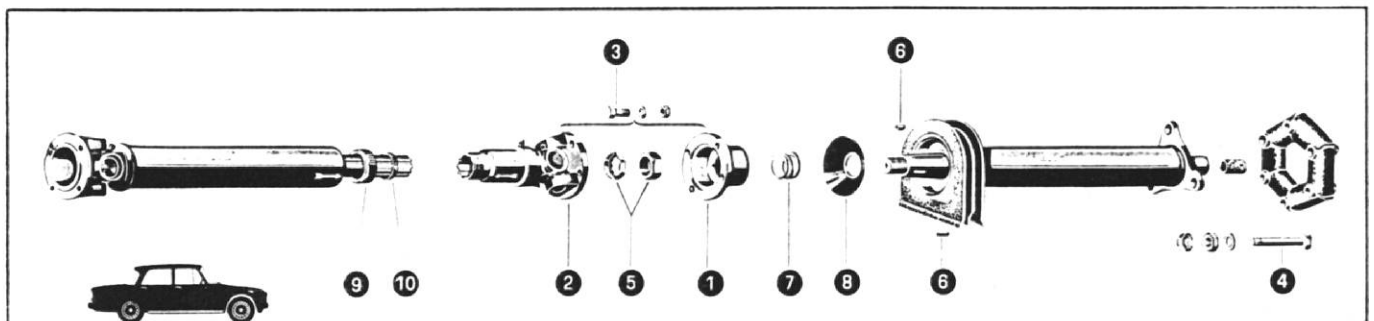
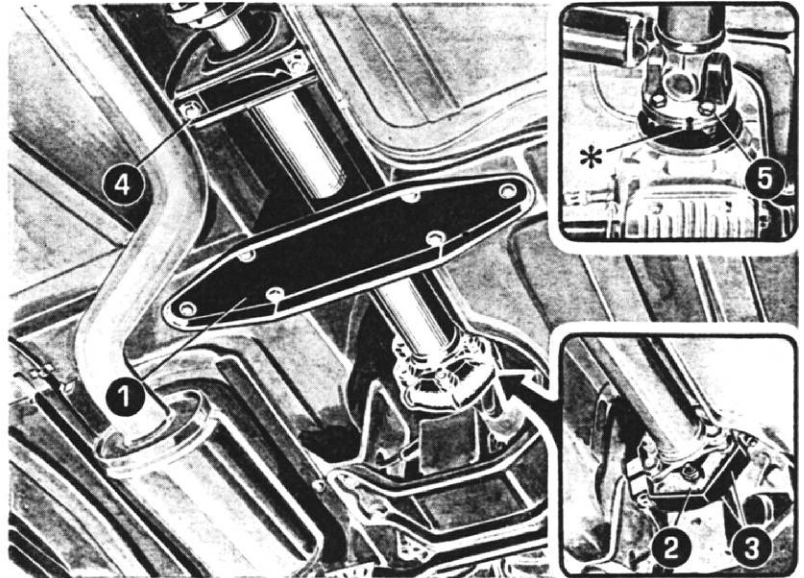

- Mark yokes 1 and 2 of front and rear section of propeller shaft for a correct reassembly; loosen bolts 3 and separate the two sections.
- If necessary, disassemble the shaft front section as follows:
 - loosen bolts 4 and remove flexible joint from yoke;
 - mark yoke 1 and front section of shaft for correct reassembly; then remove nut and palnut 5 and withdraw yoke from shaft.
- Remove keys 6, spring 7 and slingers 8.
- Unscrew the ring nut 9 and the seal 10 of yoke 2 and remove the yoke itself.

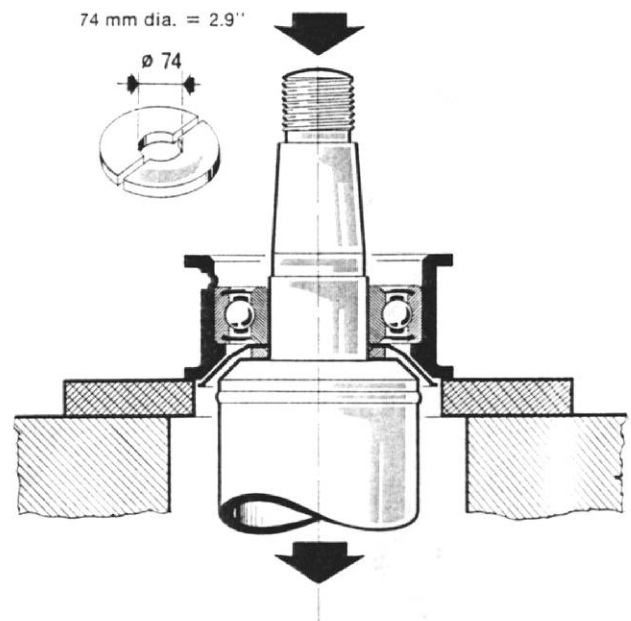

- If the bearing or support needs replacement, withdraw the support assembly by using suitable half-plates and proceeding as shown in figure.
- Take the bearing out of the support with a punch.
- Replace the support if distorted during disassembly.

INSPECTION AND CHECKING

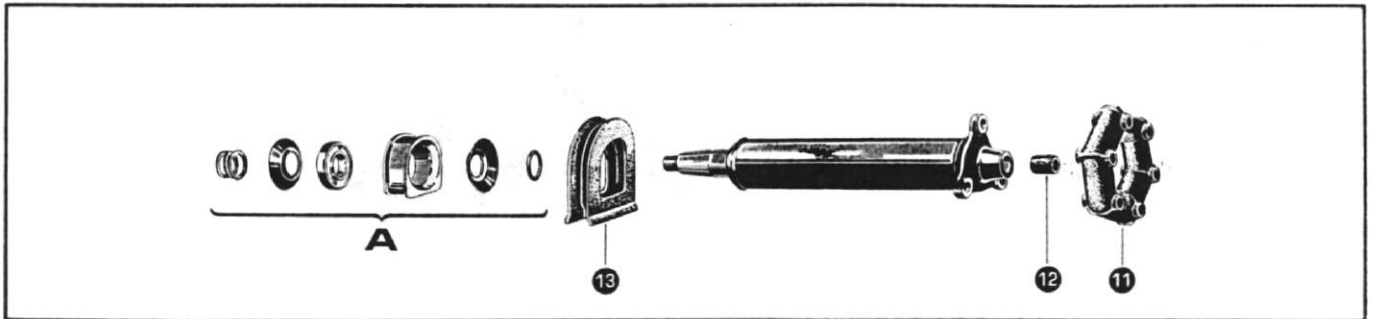

FRONT SECTION

- Check rubber collar 13 and components A of bearing assembly for sound conditions; replace damaged parts.
- Check felt 12; replace it, if necessary.
- Check rubber coupling 11 for damage or distortion; replace it, if necessary.

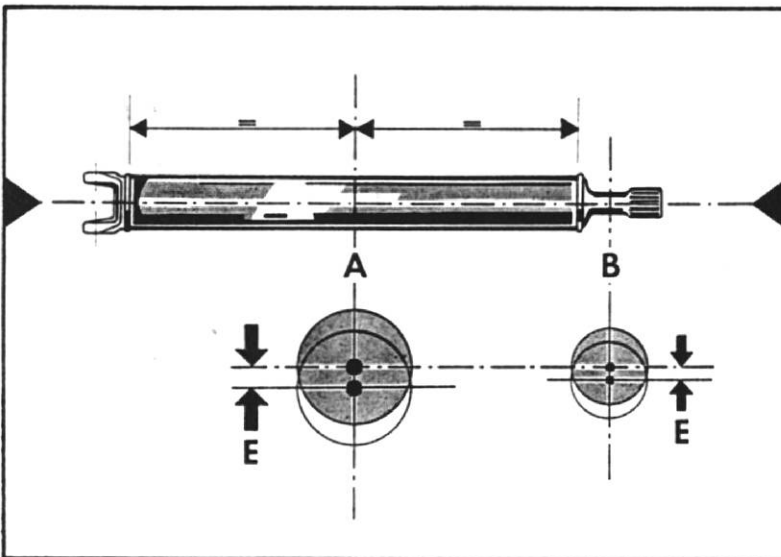

REAR SECTION

- Check the run-out E of shaft rear section at A and B:
 - max. run-out at A = .4 mm (.016")
 - max. run-out at B = .1 mm (.004")

If run-out exceeds the above limits straighten the shaft in a hydraulic press. If truing is so difficult that vibrations could take place when shaft is reinstalled, replace the shaft. If so, the whole shaft must be rebalanced dynamically.

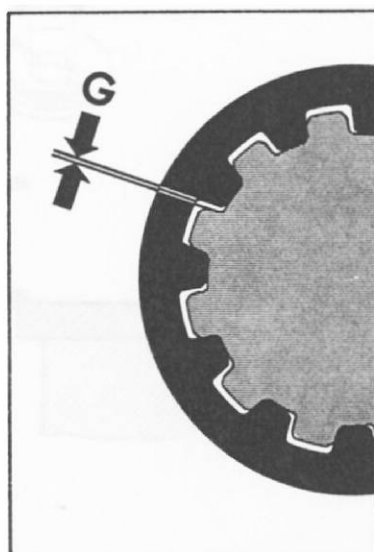

- Check the splines in the shaft and sliding yoke for good appearance; check that grease fittings on yoke and U-joints are not obstructed.
- Check yoke felt gasket: if damaged, replace it.
- Check that play G between splines is as follows:

factory setting:	.04 mm (.0016")
wear limit:	.2 mm (.0078")

REASSEMBLY

- Install the ball bearing in its seat and stake in place with a suitable punch to prevent any axial movement of the bearing.

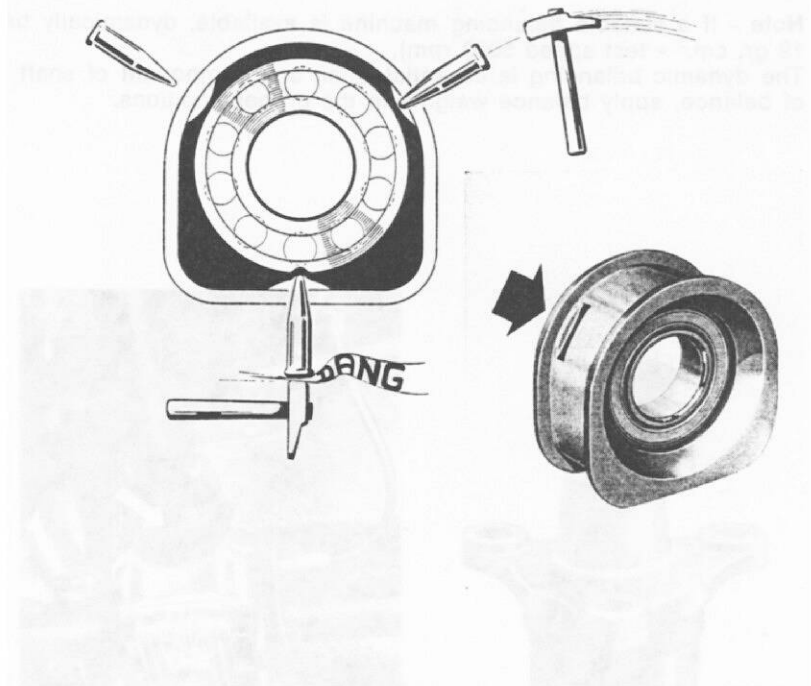

- Reassemble the front section of shaft in the following sequence:
 - the bearing spacer 14;
 - the slinger 15;
 - the bearing seat and rubber collar assembly 16;
 - the slinger 8;
 - the slinger spring 7;
 - the keys 6;
 - the yoke 1 according to the alignment marks.

Tighten nut and palnut 5.

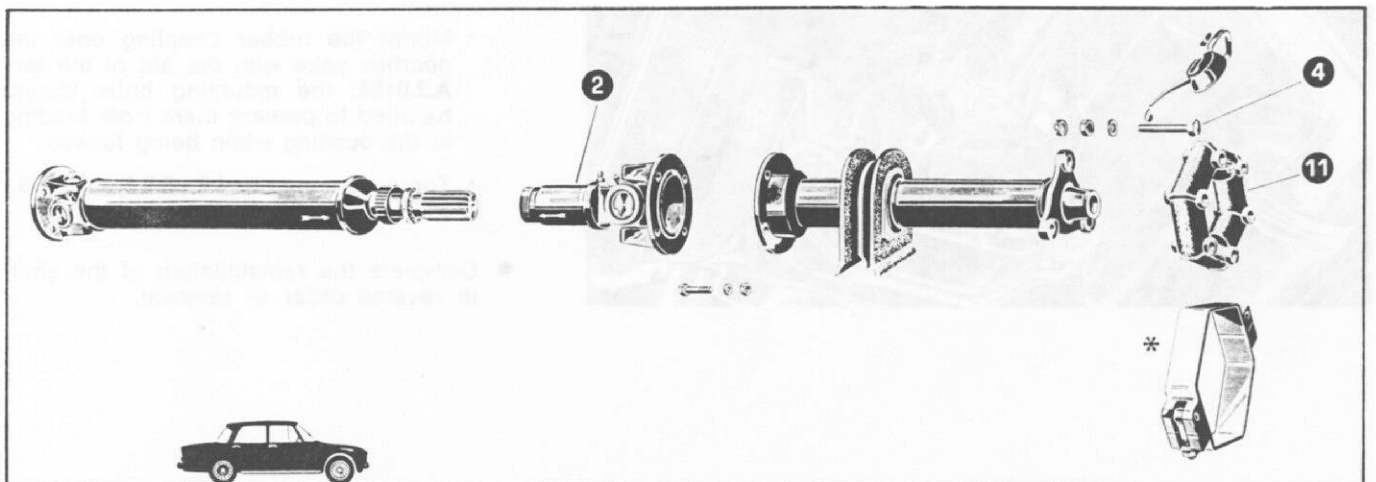
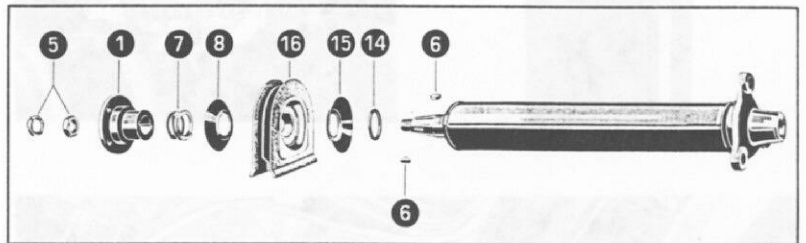

- Connect yoke 2 and rear shaft according to alignment marks.
- Join together front and rear sections of shaft according to alignment marks previously made.
- Place the rubber coupling 11 on front shaft yoke with the aid of the tool *A.2.0124; the mounting bolts should be oiled to prevent them from binding in the bushing when being locked.
- Torque the nuts on mounting bolts to 4 - 4.5 Kgm. (32.6-39.7 lb. ft.) with tool A.5.0162.

REASSEMBLY - REINSTALLATION

Note - If a suitable balancing machine is available, dynamically balance the shaft assembly (Max. out of balance 12 gr. cm.² - test speed 5000 rpm).

The dynamic balancing is essential when any component of shaft has been replaced. If the propeller shaft is out of balance, apply balance weights in the proper positions.

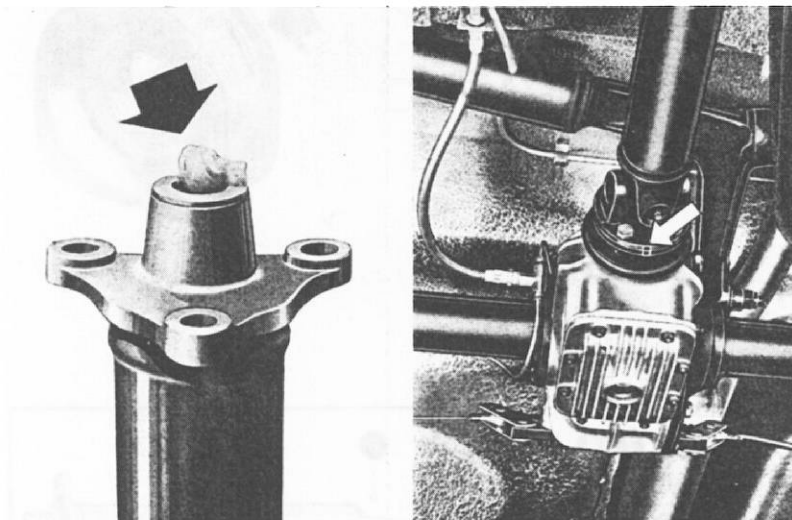

- Reinstall the propeller shaft assembly as follows:

- pack the bushing for centering prop. shaft and gearbox output shaft with grease (about 1/2 cc.) AGIP F.1 GREASE 15 - SHELL RETINAX G;
- Connect shaft yoke to differential yoke according to alignment marks previously made;
- torque the nuts of connecting bolts to **3.5-4 Kgm** (25.3 - 28.9 lb-ft) with tool **A.5.0162**.

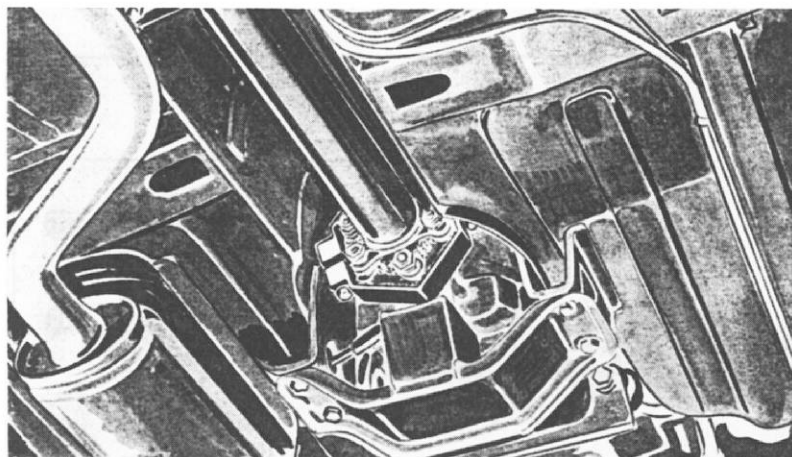

- Mount the rubber coupling onto the gearbox yoke with the aid of the tool **A.2.0124**; the mounting bolts should be oiled to prevent them from binding in the bushing when being locked.
 - Torque the nuts to **4.5 - 5.5 Kgm** (32.6 - 39.7 lb-ft) with tool **A.5.0162**.
- Complete the reinstallation of the shaft in reverse order of removal.

REAR AXLE AND SUSPENSION

GENERAL

The live axle is attached to the body through:

- two rubber-bushed radius rods which counteract tractive and braking efforts longitudinally;
- a trunnion reacting to transversal efforts and mounted on rubber bushings;
- vertical coil springs secured to the radius rods and telescopic hydraulic shock absorbers coaxial with the springs.

Upward movement of rear axle is restricted by bumper pads and downward by rebound straps. The differential, with the hypoid final drive, is housed in the aluminum carrier to which the two axle tubes enclosing the semifloating axle shafts are connected.

A magnetic plug in the carrier retains metal particles suspended in the oil.

OVERALL GEARBOX / REAR AXLE RATIOS

Final drive		41 : 8	41 : 9	43 : 9	41 : 10	41 : 11
Gear	1st	16.933 : 1	15.049 : 1	15.783 : 1	13.546 : 1	12.314 : 1
	2nd	10.189 : 1	9.055 : 1	9.496 : 1	8.151 : 1	7.409 : 1
	3rd	6.944 : 1	6.172 : 1	6.472 : 1	5.555 : 1	5.050 : 1
	4th	5.125 : 1	4.555 : 1	4.777 : 1	4.100 : 1	3.727 : 1
	5th	4.054 : 1	3.603 : 1	3.778 : 1	3.243 : 1	2.948 : 1
	Rev.	15.426 : 1	13.710 : 1	14.378 : 1	12.341 : 1	11.218 : 1
GIULIA 1300 (4 speed)			■			
GIULIA 1300 ti		■				
GIULIA TI		■	□		□	
GIULIA TI SUPER		■	□	□	□	□
GIULIA SUPER GIULIA SPRINT GT GIULIA SPRINT GT Veloce GIULIA GTC			■			
SPIDER 1600			■			

■ standard
□ optional

REAR AXLE

IN-CAR REPAIRS



IN-CAR REPAIRS

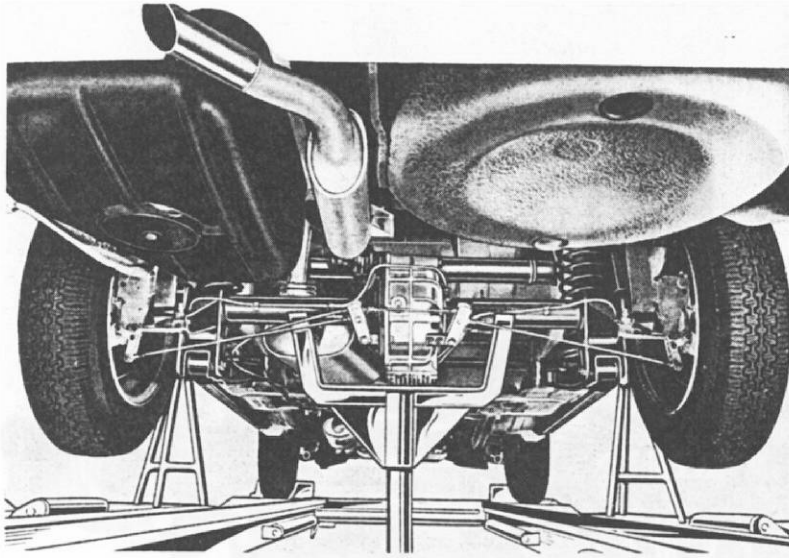

Axle shaft, wheel bearings and packing replacement

- Loosen the wheel nuts;
- Jack up the car as shown and put stands under the jack sockets;
- Remove the wheels and lower the lift.

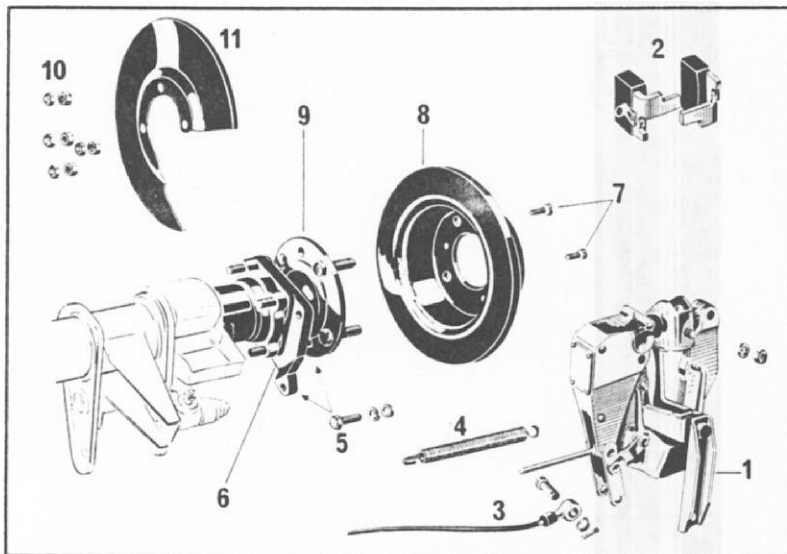

- Free the pad retaining plate 1 at one end only and take the pads out;
- Disconnect the hand brake cable 3;
- Remove the return spring 4 from both attachment points;
- Loosen screws 5 fastening the brake caliper to its bracket 6; remove the caliper by withdrawing the push rod from slave cylinder;
- Loosen screws 7 attaching the brake disc 8 to wheel hub 9 and remove the disc;
- Unscrew nuts 10 securing the bearing housing to axle tube and remove the splash shield 11.

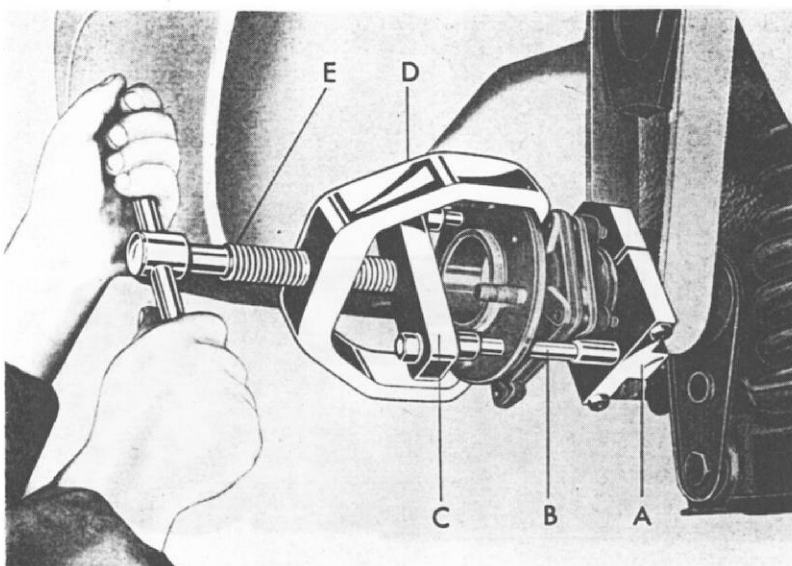

- Withdraw the axle shaft as follows (Ref. Tool Bulletin no. 33/2);
- Install the abutment A, tool A.3.0109/1, on axle tube;
- Pass offset pins B of the tool A.3.0109 through the holes into the axle shaft flange and tighten by hand the nuts against the plate C;
- Mount the puller D as shown and withdraw the axle shaft by turning the screw E.

IN-CAR REPAIRS

- If necessary, remove the axle shaft bearing as follows:
 - unscrew the bearing ring nut with the tool **A.5.0120**;

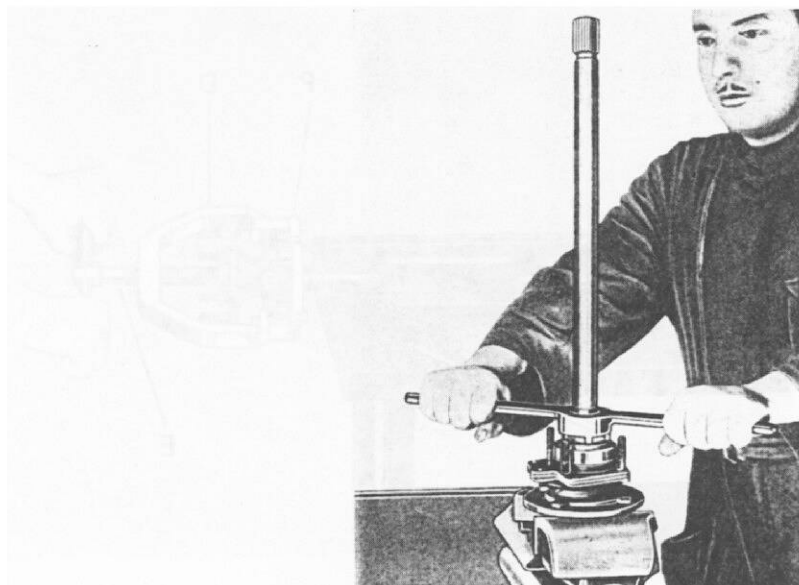

- mount the plate **P** of tool **A.3.0109** (Tool Bulletin no. 33/2) on the bearing housing and tighten the nuts;
- pass the offset pins **B** through the holes into the shaft flange so that they rest against the bearing housing;
- mount the puller **D** onto the shaft flange making sure the screw **E** is perfectly centered and withdraw the shaft.

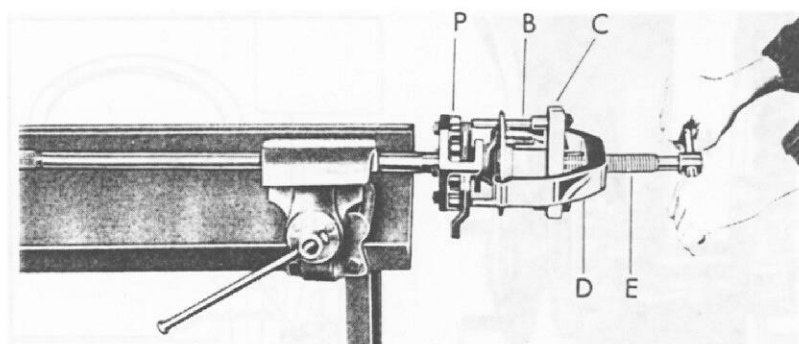

Withdrawing the axle shafts from cars with drum brakes

- loosen the attaching screws and remove the brake drums;
- loosen the nuts fastening the shoe back plates to axle tube;
- pass offset pins **B** of the tool **A.3.0109** (Tool Bulletin no. 33/2) through the holes into the axle shaft flange against the plate **T**;
- mount the puller **D** as shown and withdraw the shaft by turning the screw **E**.

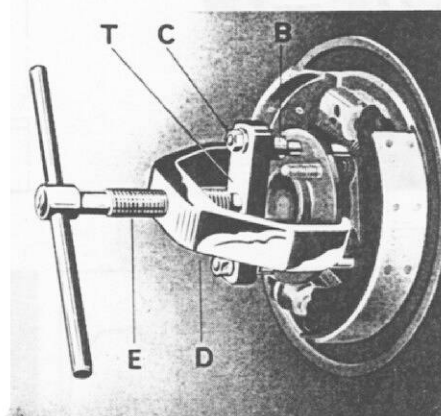

Inspection and check

- Check the conditions of oil seal packing; replace it, if necessary. To refit the packing use tool **A. 3.0160**.
- Check the run out of axle shaft with a dial indicator:

maximum run out: .10 mm (.0039")

Minor adjustment is possible by cold straightening the axle shaft with a suitable press. Replace the shaft, if necessary.

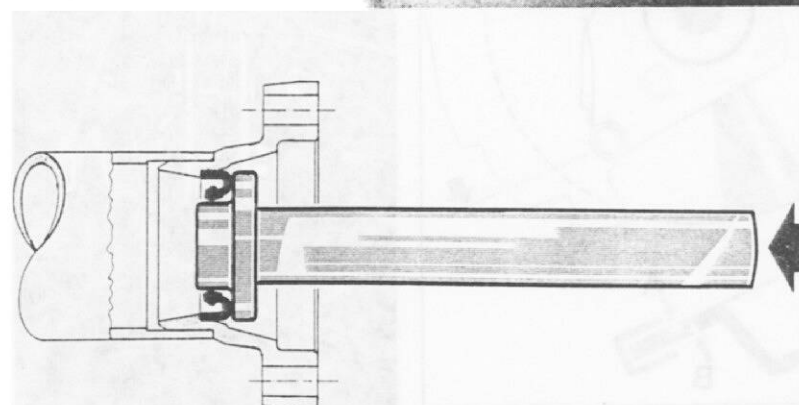

IN-CAR REPAIRS

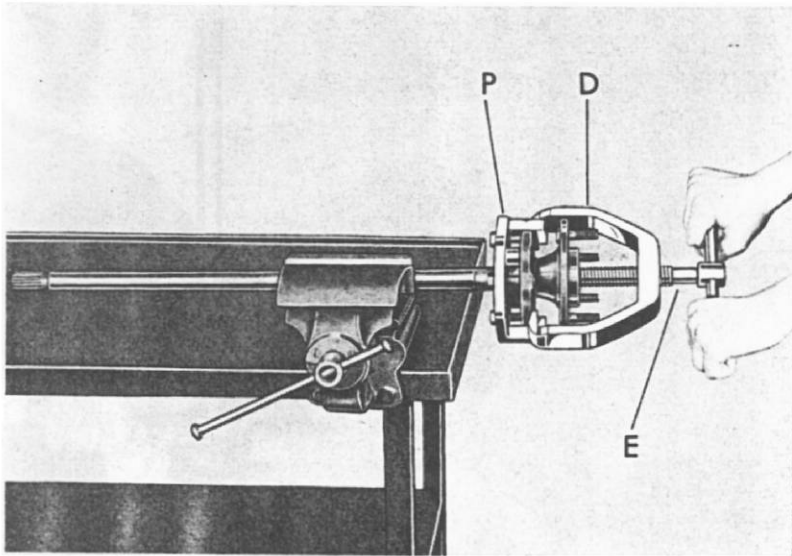

Reassembly

- Install bearing housing and bearing onto axle shaft; to insert bearing, proceed as follows (Tool Bulletin no. 33/2):
 - mount the plate **P** of tool **A.3.0109** on bearing housing and tighten the nuts;
 - engage the puller **D** with the brackets of plate **P**;
 - the bearing can now be driven in place by turning the screw **E** against the end of the shaft as shown;
 - screw in the bearing ring nut with tool **A.5.0120**;
 - Bend the tabs of tabwasher.

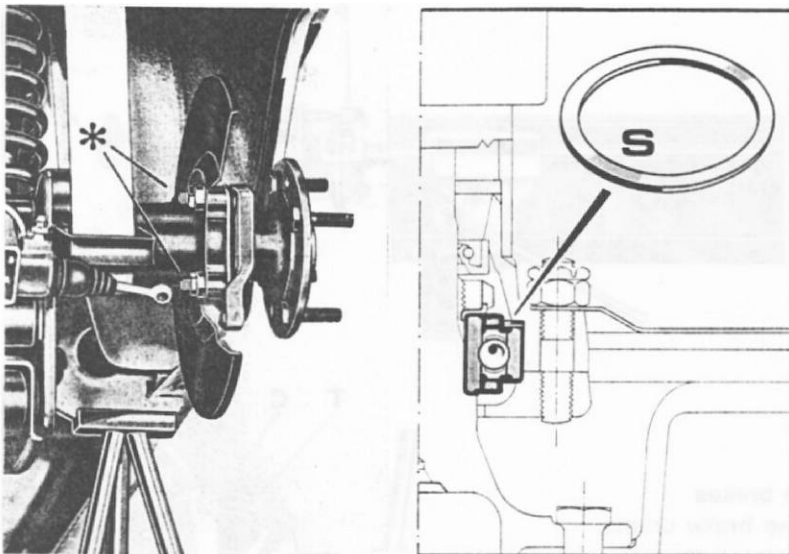

- Insert the axle shaft into axle tube and start axle splines into side gear, taking care not to damage the oil seal packing and the baffle in the axle tube.
- Push shaft in until it bottoms by tapping with a mallet on a punch placed in the shaft flange hollow.
- Install the splash shield on caliper bracket and torque the attaching nuts * to **4.8 - 5.5 Kgm (34.8 - 32.7 lb-ft.)** with the tool **A.5.0146**; secure with the pal nuts.
- After installation, check that the axle shaft has no end play: if any play exists, take it up by inserting shims **S** as required between outer race of bearing and bearing housing.

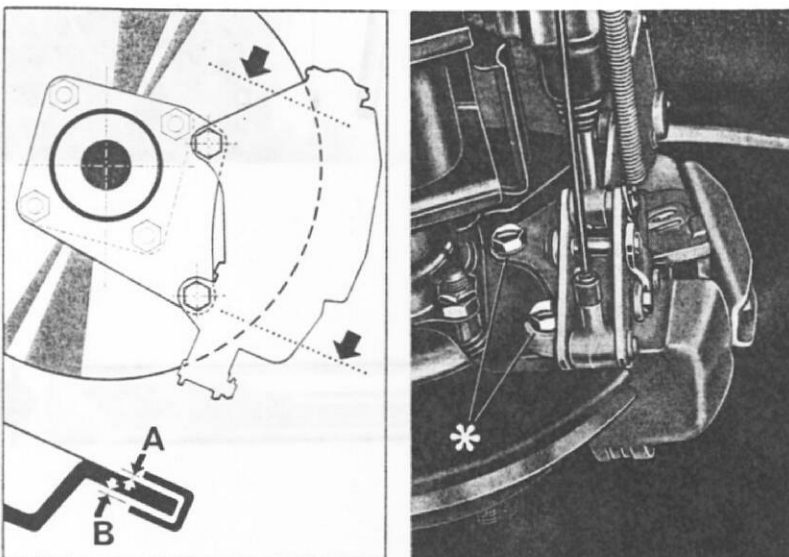

- Mount the caliper to its bracket keeping in mind that:
 - the difference in gap **A** and **B** between disc and caliper on each side should not exceed **.5 mm (.02")**; if necessary, insert shims between caliper and bracket;
 - torque the bolts * attaching caliper to bracket to **2.3 - 2.8 Kgm (16.7 - 20.2 lb-ft.)**.

REMOVAL

- Place the car on a lift and drain oil from differential;
 - loosen the wheel nuts;
 - jack up the rear end of car as shown and put stands under the jack sockets;
 - remove the wheels;

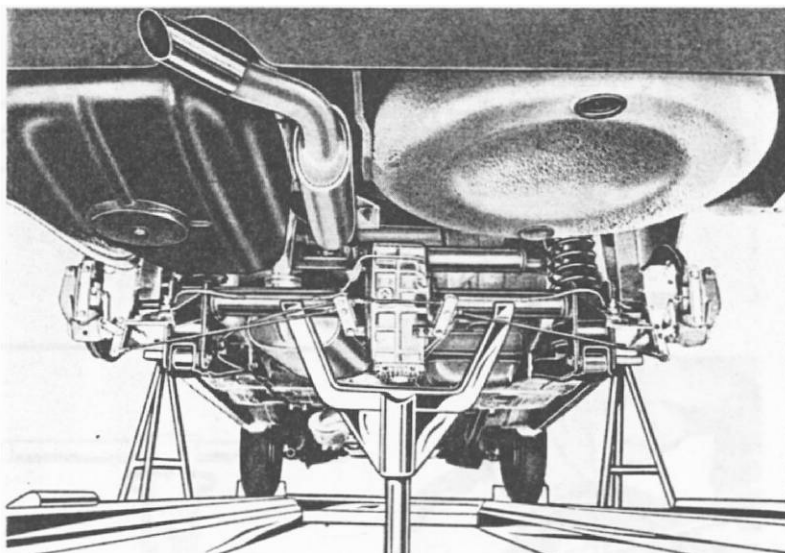

- 1 Disconnect the brake lines from three-way union;
- 2 loosen bolts attaching propeller shaft to differential;
- 3 remove cotter pin and nut attaching reaction trunnion to rear axle;
- 4 withdraw pins connecting hand brake cables to shackles at the differential carrier;
 - disconnect hand brake cables from levers at the brake calipers;
- 5 Unscrew the nuts attaching shock absorbers to suspension radius rods, remove rubber pads and fully collapse the shock absorbers;
- 6 loosen the screws attaching the rebound straps and bumper pads; to do this easily, raise the rear axle so as to unload the straps.

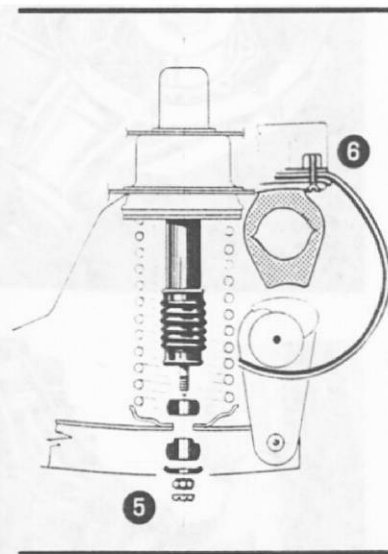
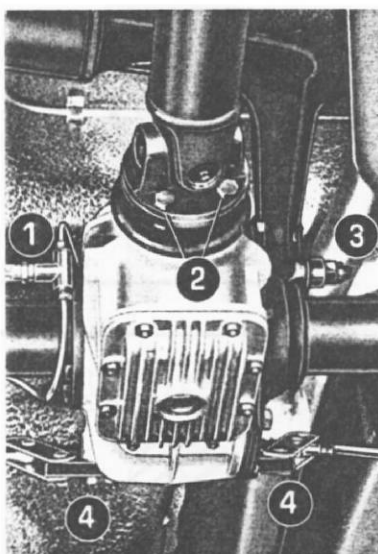

- Insert pin **B** of tool **A.2.0143** (Tool Bulletin no. 114) into the holes of radius rods attaching lugs;
 - rotate handle **D** until the bracket **F** of tool rests firmly against the radius rod attachment;
 - pass the wrench through the port in the tool and unscrew the nut on the bolt mounting the radius rod to rear axle;
 - rotate handle **D** in such a way as to lower the bracket **F** and to relieve the spring;
 - remove the special tool and get the rear axle free from the reaction trunnion by slightly shifting the axle toward the off side;
 - put down the axle by lowering the jack.

Cars with drum brakes

- Hook the tool **A.2.0143** up to the axle tube with the beak **A** and rotate handle **D** until the bracket **E** rests firmly against the radius rod attachment;
 - remove the rear axle the same way as directed for cars with disc brakes.

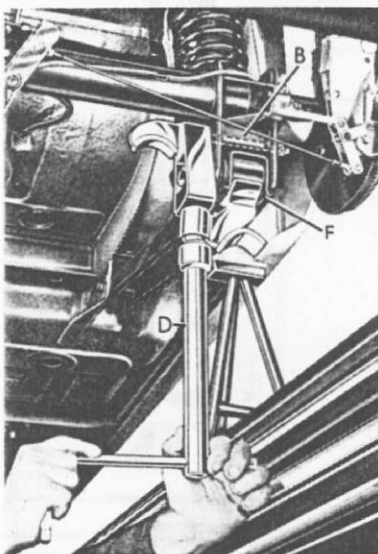

DISC BRAKES

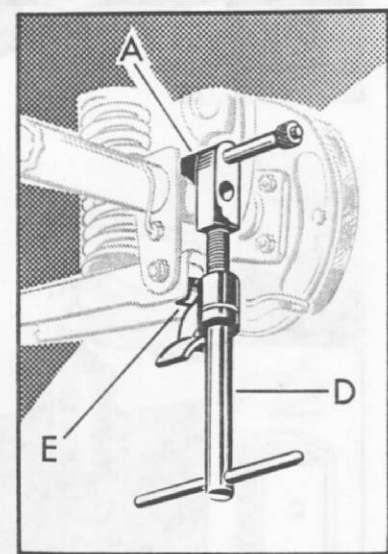

DRUM BRAKES

DISASSEMBLY ON BENCH

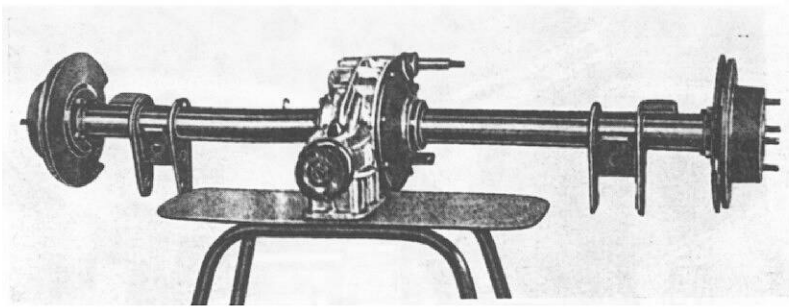

- Place the rear axle on a suitable stand;
- Remove:
 - brake caliper assemblies;
 - brake discs and axle shafts (refer to page 14);
 - axle tubes;
 - and disassemble the differential carrier.

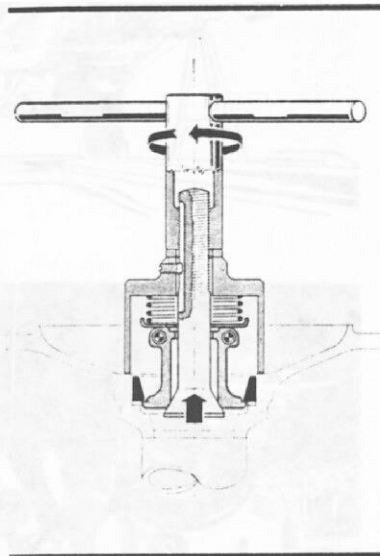
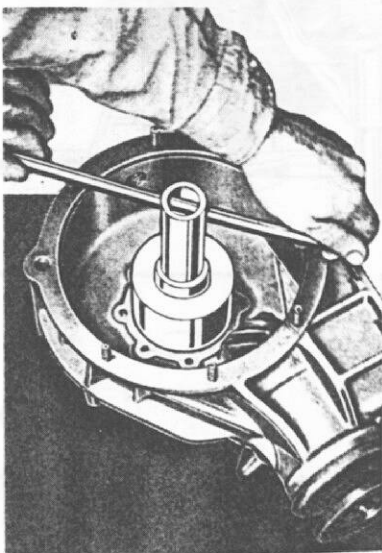

- If necessary, withdraw the bearing cups from differential carrier and left-hand axle tube with tool **A.3.0115**; take out and retain the shims. For withdrawal, set the parts upright and proceed as shown in the illustrations.

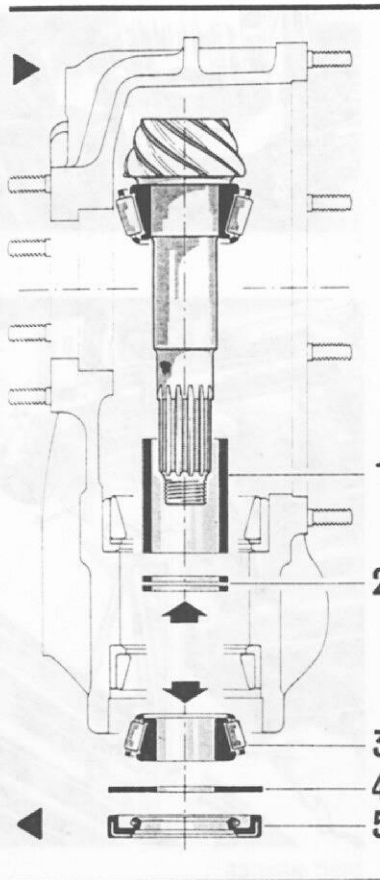
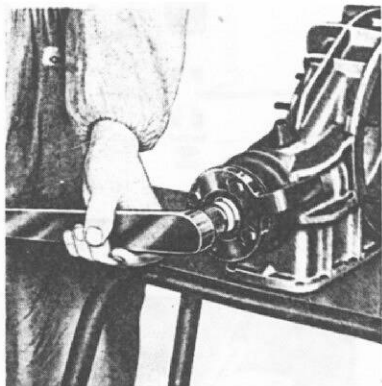

- Remove final drive pinion and shaft from differential carrier as follows:
 - free the flange securing ring nut from the tabwasher;
 - install tool **A.2.0144** (Tool Bulletin no. 116) onto the flange with the suitable bolts to prevent the pinion from rotating when unscrewing the ring nut;
 - insert the bushing **A.5.0104** (Tool Bulletin no. 74/1) and unscrew the ring nut;
 - withdraw the pinion & shaft assembly from carrier by tapping with a soft mallet;
 - slide out spacer **1** and retain shims **2**;
 - remove the oil seal packing **5**, the slinger **4** and the front bearing cone **3** from differential carrier.
- If necessary, withdraw the rear bearing cone with tool **A.3.0150** (Tool Bulletin no. 92); for withdrawal, fit the half rings **A** (of the proper type) onto the pinion and rest the parts so arranged against the base **C**; to slide out the bearing, tap lightly on pinion shaft end with a soft mallet.

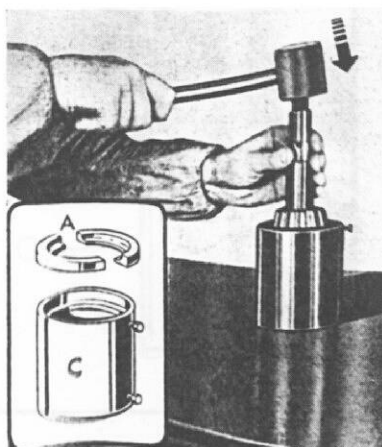

DISASSEMBLY ON BENCH - INSPECTION AND CHECKING

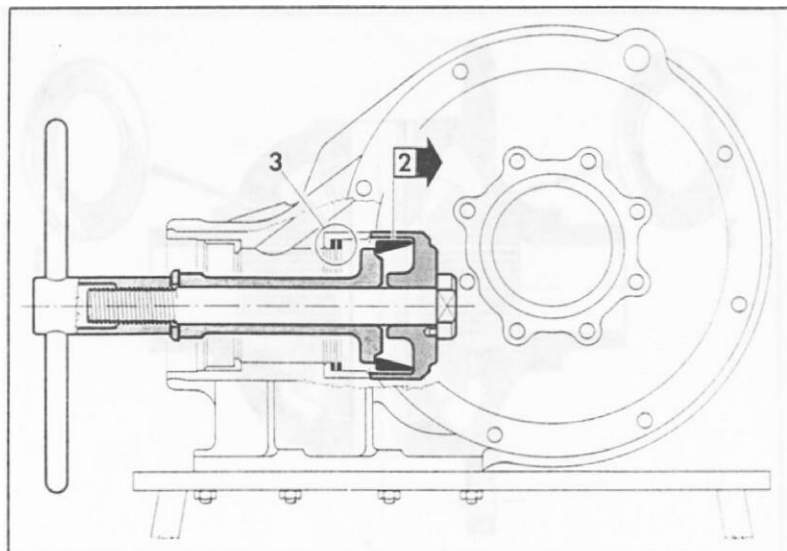
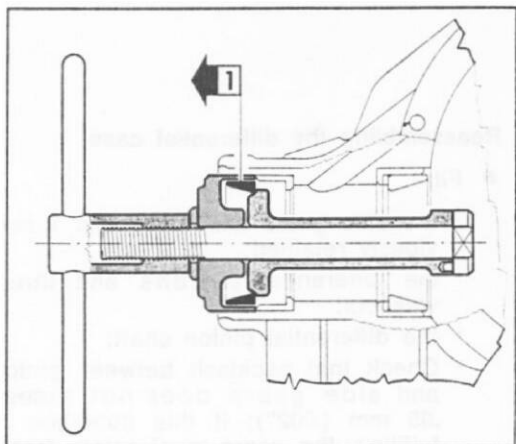

- With tool **A.3.0207** (Tool Bulletin no. 100/1) withdraw:
 - 1 front bearing cup;
 - 2 rear bearing cup.
 Remove and retain shims **3**.

Differential case

- If necessary, pull the bearing cones out of differential case with tool **A.3.0212** (Tool Bulletin no. 128).
- Loosen the screws attaching the ring gear to differential case after unlocking from tabwashers; then countermark and remove the ring gear from case.
- Drive out the shaft of differential pinions from the side opposite the key; take out pinions and side gears with their shims.

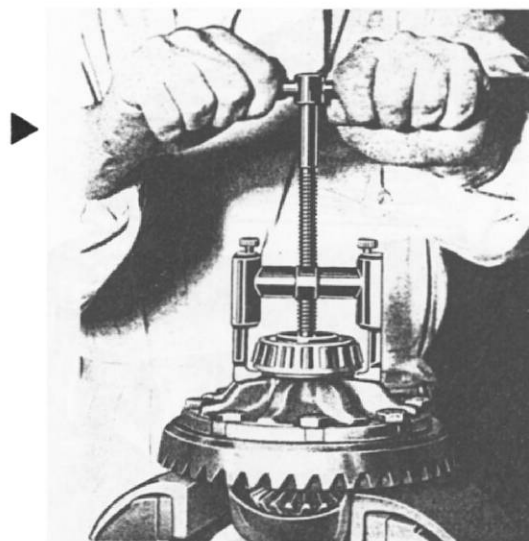

INSPECTION AND CHECKING

a) Final drive.

Check the pinion and ring gear teeth for any sign of binding or excessive wear. If teeth are badly worn, replace the pinion and ring gear assembly.

WARNING - Pinion and ring gear are supplied as a matched set only, therefore they are not available separately.

b) Roller bearings.

Check pinion bearings (**3** and **4**) and differential case bearing **5** for any sign of scoring, scratching, binding or excessive wear; replace them, if necessary.

c) Differential pinion and side gears.

Check teeth of gears **6** and **7** for scoring, dents or excessive wear.

- Check the differential pinion shaft **8** for sign of binding or excessive wear; replace damaged parts, if necessary. Clean all the components thoroughly.

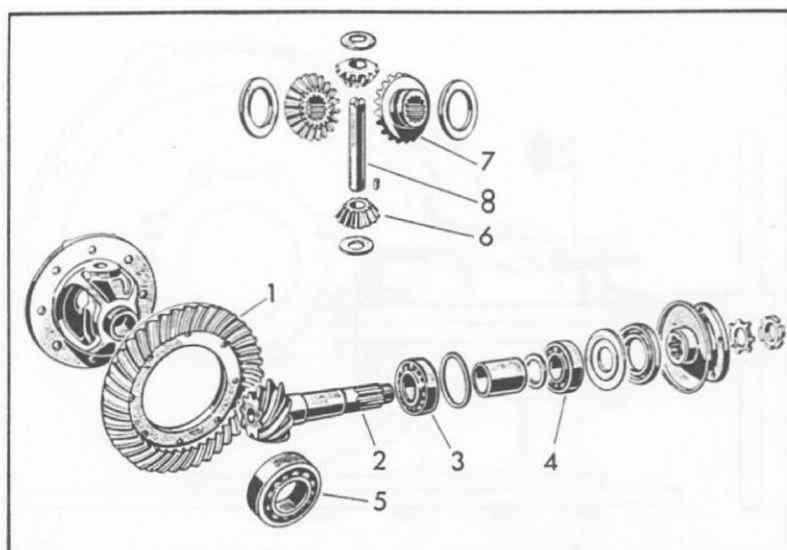

REASSEMBLY ON BENCH

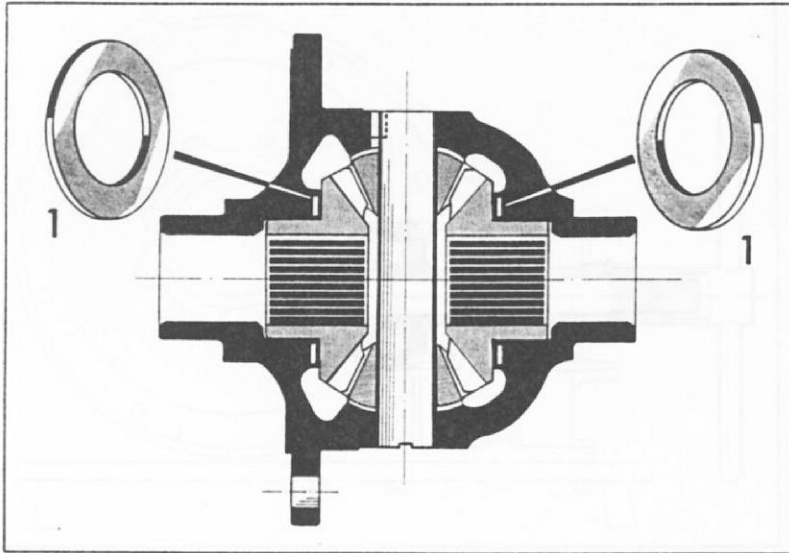

Reassembling the differential case

- Fit:
 - the side gears and the shims 1 previously retained;
 - the differential pinions and thrust washers;
 - the differential pinion shaft;
 - Check that backlash between pinion and side gears does not exceed **.05 mm (.002")**; if this condition is fulfilled, **the gears must rotate freely by hand**.
To adjust the backlash, insert or remove shims 1 as required between the side gears and differential case.

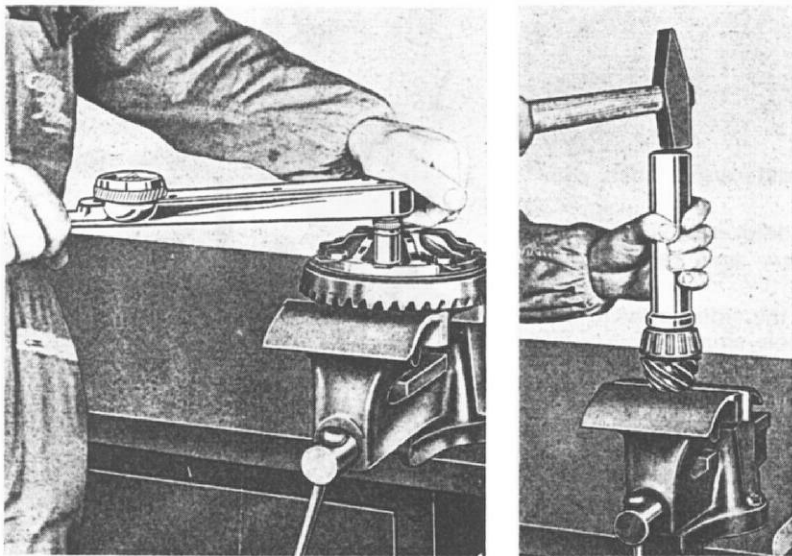

- Install the ring gear according to the markings previously made on differential case and dry torque the attaching screws to: **4.5-5.0 Kgm (32.6-36.1 lb-ft)**.
- Safety lock the screws with the tab-washers.

Reassembling final drive pinion

- Drive rear bearing cone onto pinion shaft with the tool **A.3.0170**.

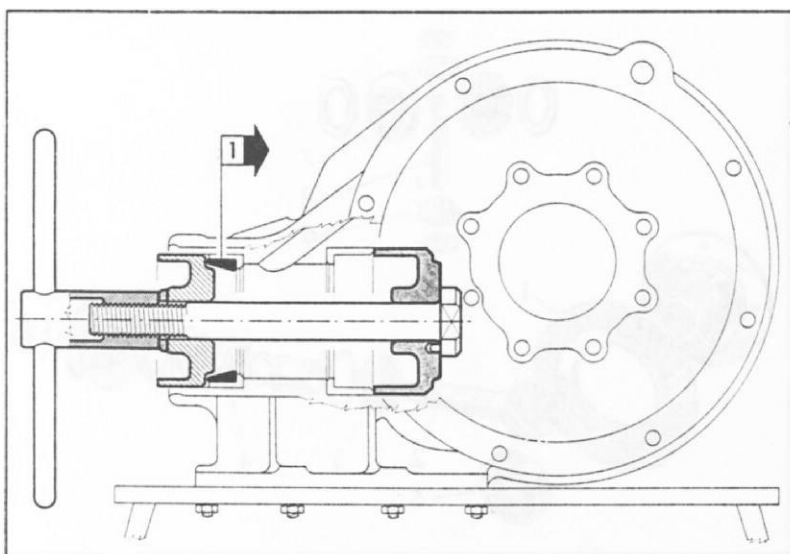

- With tool **A.3.0207** (Tool Bulletin 100/1) drive into their seats: **1** pinion front bearing cup;

REASSEMBLY ON BENCH

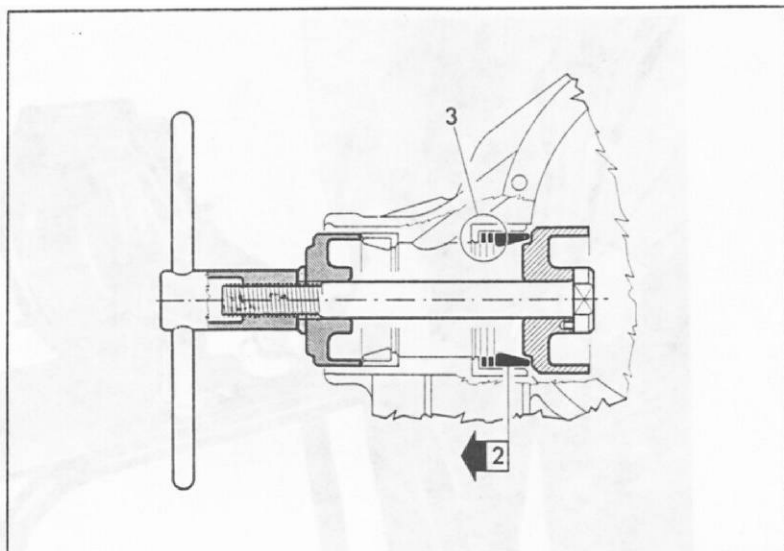

2 shims 3 and pinion rear bearing cup.

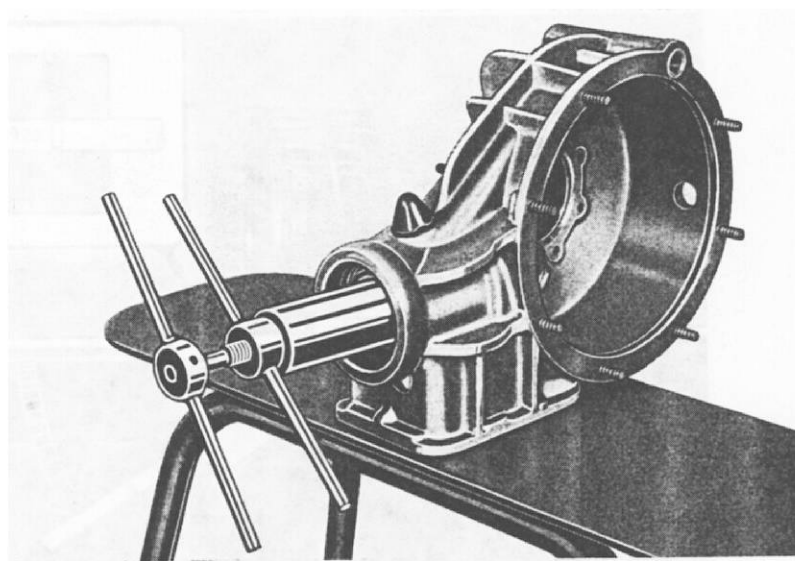

- Drive onto pinion shaft:
 - 1 the bearing spacer;
 - 2 the shims previously retained.
- At this stage of assembly insert the pinion into differential carrier.
- Then assemble:
 - the front bearing cone 3 with tool **A.3.0168**;
 - the slinger.

Warning: do not install the oil seal packing.

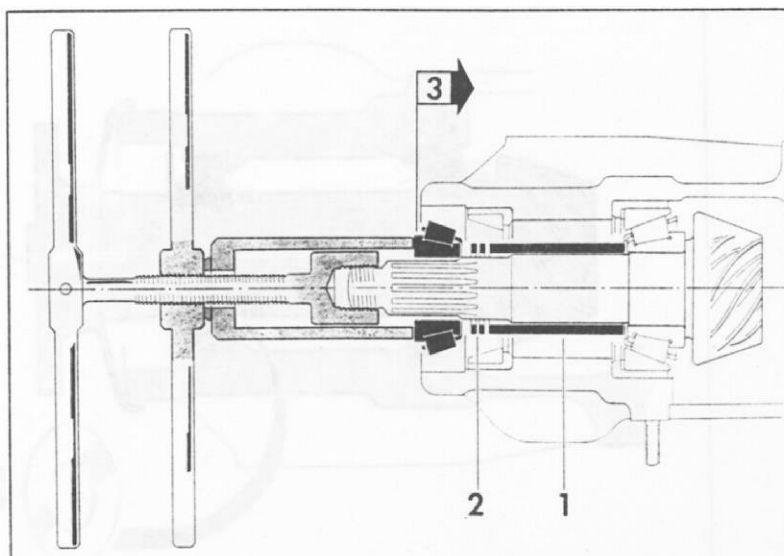

REASSEMBLY ON BENCH

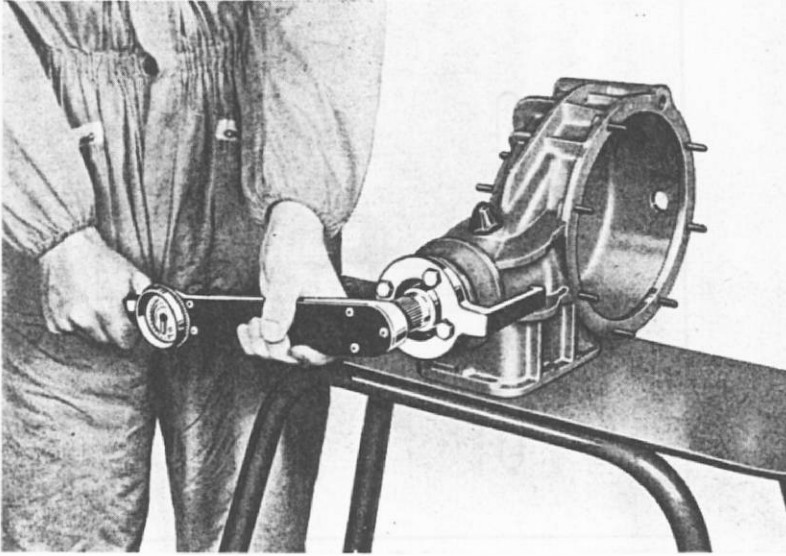

- Assemble the flange on pinion shaft and tighten the ring nut to **8-14 Kgm** (58 - 100 lb-ft); before tightening, insert bushing **A.5.0104** and prevent pinion from rotating with tool **A.2.0144**.

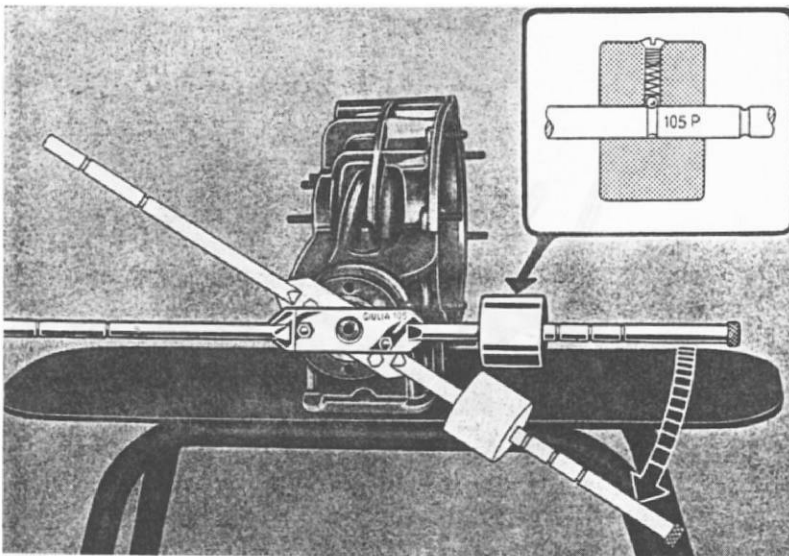

Checking the pre-load of pinion bearings

- Install the tool **C.5.0100** (Tool Bulletin no. 20/1) on the flange;
 - rotate the tool in both directions to settle the bearings;
 - position the weight in the slot marked 105 P;
 - check that, when leaving the tool arm free in horizontal position, the weight moves downward slowly through about 30 degrees.In such a condition the pre-load is correct and the revolving torque should be:
11.5 - 15.5 Kgcm (10 - 13.5 lb-in.).

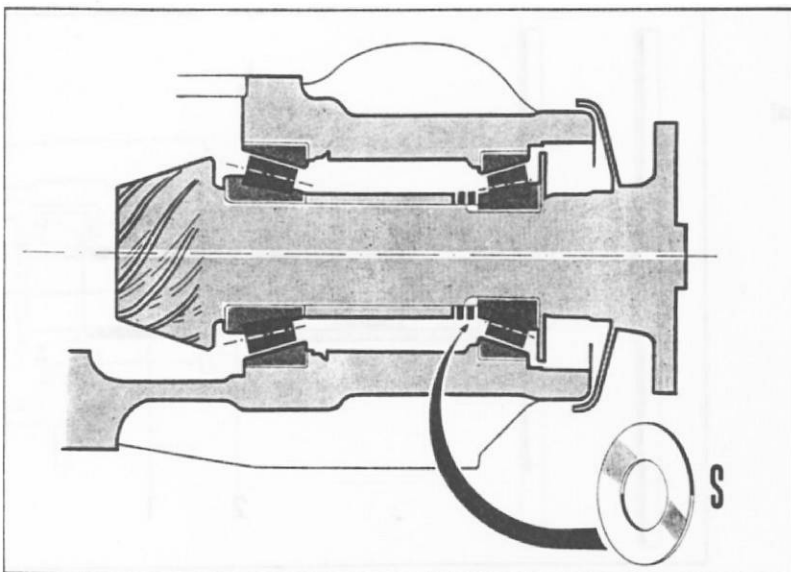

- If this is not the case, remove pinion from differential carrier and change thickness of shims between spacer and bearing cup taking in mind that:
 - **adding shims decreases the pre-load;**
 - **removing shims increases the pre-load.**
- Proceed by trial and errors until the correct pre-load is obtained.

REASSEMBLY ON BENCH

Checking and adjusting the distance of final drive pinion from ring gear center line

- The distance **B** from pinion top to ring gear center line should be 57 mm plus or minus the value (in hundredths of millimeter) metal stamped on pinion head.
- Specifically: if this value is preceded by the plus mark, the distance shall be 57 mm plus the figure stamped on pinion and viceversa.
- To check proceed as follows:
 - withdraw the R.H. bearing cup from differential carrier with tool **A.3.0115** (see page 18);
 - place the dummy shaft **U** (tool **C.6.0114** see Tool Bulletin no. 27/1) in the R.H. bearing seat and fasten in place by tightening nut **C** manually;
 - mount a dial indicator on the support **V** (tool **C.5.0116**) and zero set the dial against the reference gauge **C.6.0101** to the nominal dimension **D** = 70 mm. The dimension **D** (70 mm) corresponds to the distance between the pinion top surface and the generating line of dummy shaft **U**.

$$70 \text{ mm} = 57 \text{ mm (B)} + \frac{\text{dummy shaft dia.}}{2}$$

- Rest the dial indicator support against the pinion top and check that the readings recorded (positive or negative with respect to **D**) are in accordance with the figure stamped on pinion both in sign and value.
- If this condition is not fulfilled, the pinion must be readjusted to correct assembly position by varying the thickness of shims **S₁** in between the rear bearing cup and the seat in differential carrier:
 - add shims to bring the pinion nearer to ring gear;
 - remove shims to bring the pinion farther off the ring gear.

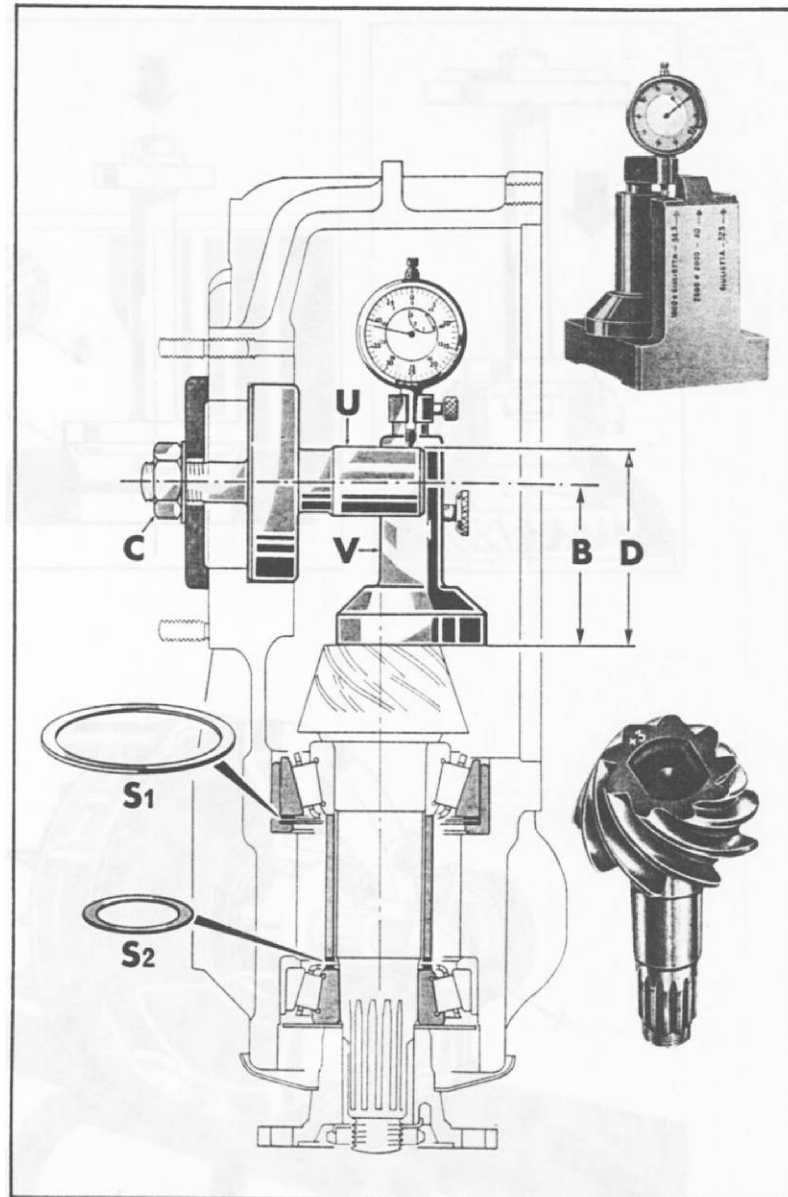

ACTUAL EXAMPLE

	D.I.R.	Mark on pinion	Adjustment
1st example	- 4	+ 2	- 6 (subtract)
2nd example	+ 4	- 2	+ 6 (add)
3rd example	- 2	+ 4	- 6 (subtract)
4th example	+ 2	- 4	+ 6 (add)
5th example	- 4	- 2	- 2 (subtract)
6th example	+ 4	+ 2	+ 2 (add)
7th example	- 2	- 4	+ 2 (add)
8th example	+ 2	+ 4	- 2 (subtract)

ADJUSTMENT **S₁** = (algebraic subtraction) (± Dial indicator reading) minus (± Mark on pinion)

Warning: in order not to alter the pinion bearing pre-load, it is necessary also to add or remove shims **S₂** in between spacer and front bearing cone accordingly.

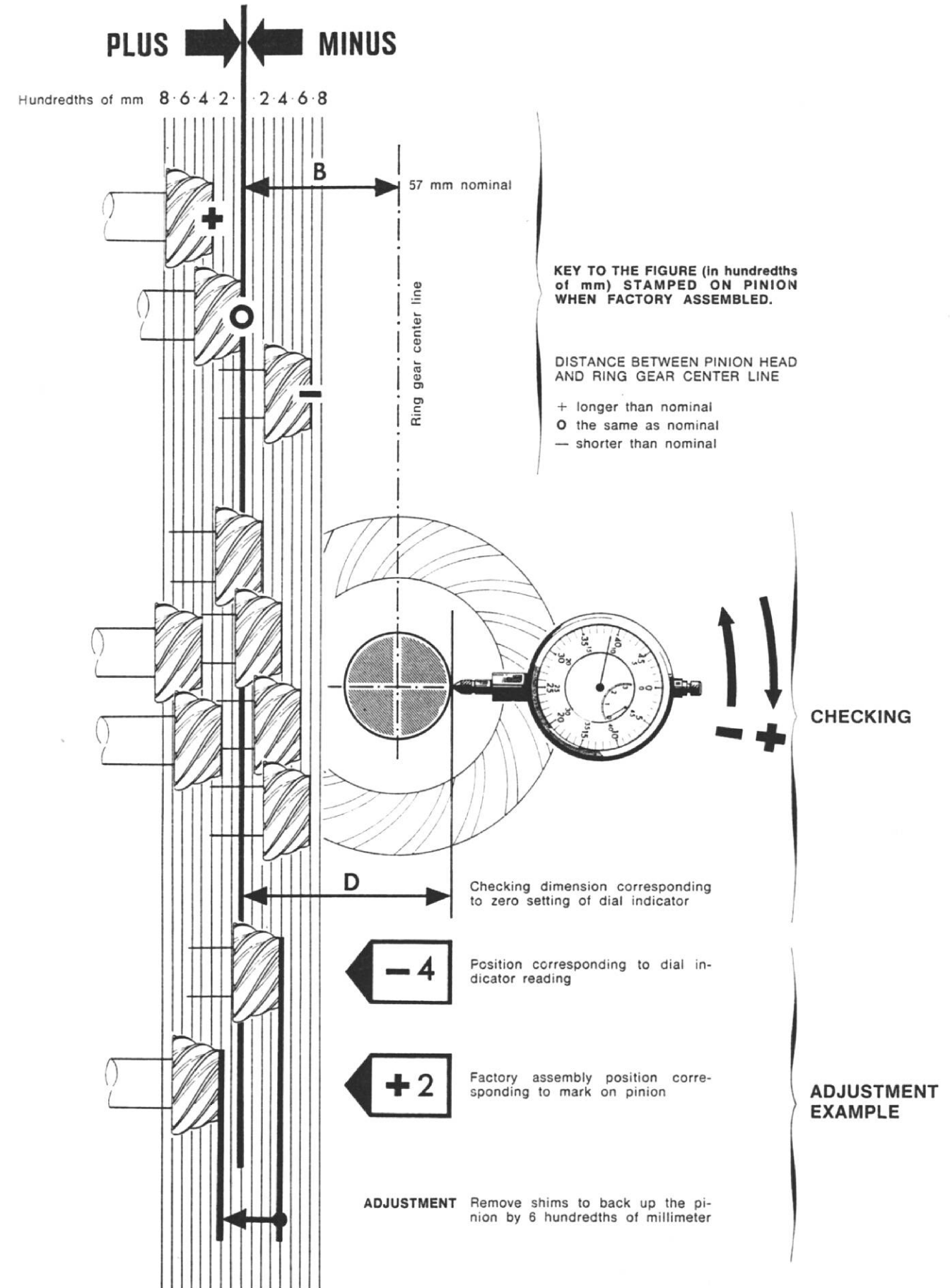

REASSEMBLY ON BENCH

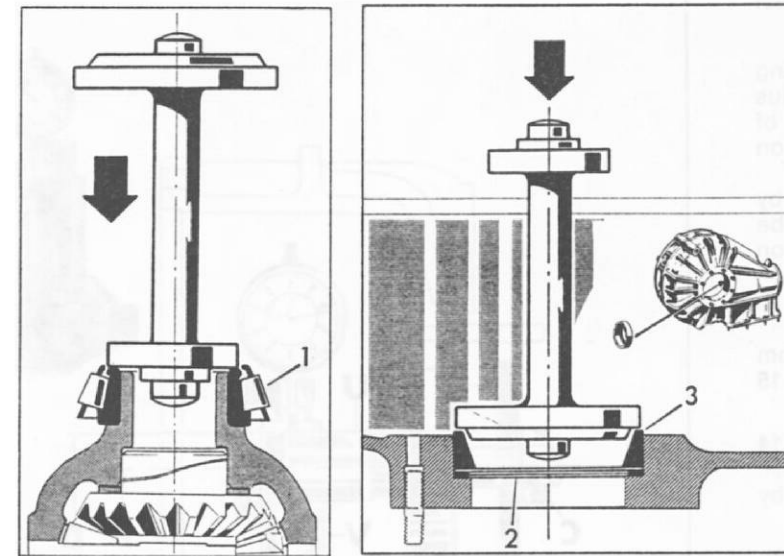

Checking the total pre-load of pinion & ring gear bearings

- Drive cones 1 of side bearings onto differential with tool **A.3.0208**.
- Into R.H. bearing seat in differential carrier insert:
2 shims previously retained;
3 bearing cup with tool **A.3.0208**.
- Assemble the differential case assembly to the differential carrier.

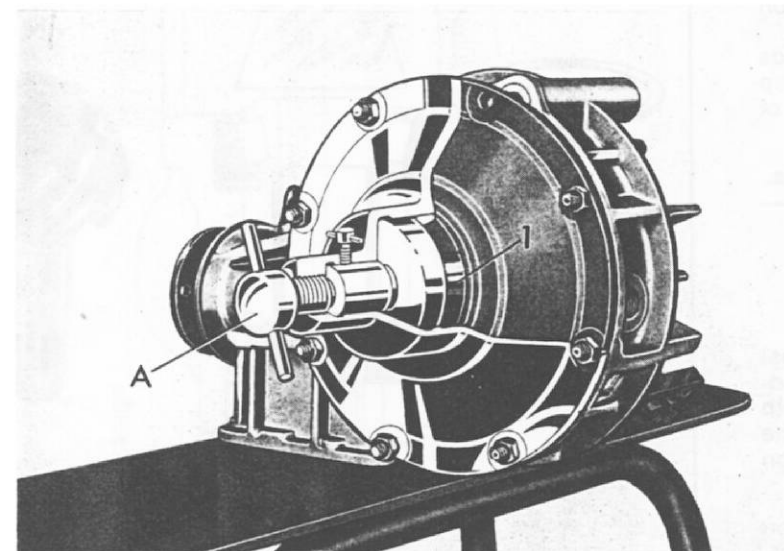

- Place the cup 1 of differential carrier L.H. bearing on tool **C. 6.0115** (Tool Bulletin no. 102/2);
• mount the tool so arranged on L.H. flange of differential carrier and fasten with nuts;
• rotate handle **A** until a provisional clearance is obtained between pinion and ring gear.

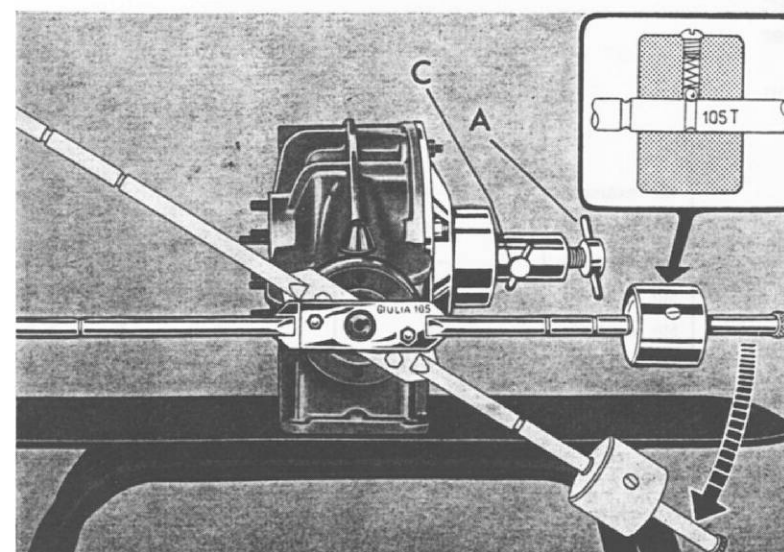

- Install the tool **C.5.0100** (Tool Bulletin no. 20/1) for checking the bearing pre-load on pinion shaft flange;
- rotate the tool in both directions to settle the bearings;
- position the weight in the slot marked 105 T and check that, when leaving the tool arm free in horizontal position, the weight moves downward slowly through about 30 degrees.
In such a condition the total revolving torque of pinion and ring gear should be:
16.5 - 24.5 Kgcm (14.5 - 21 lb-in.).
If this is not the case, rotate handle **A** of tool **C.6.0115** until the prescribed pre-load is obtained.
Then lock the setscrew **C**.

Note: the pre-load shall be checked in four different position of the ring gear; to do this, rotate the pinion of a complete turn after each check.

ADJUSTING THE DISTANCE OF FINAL DRIVE PINION FROM RING GEAR CENTER LINE

REASSEMBLY ON BENCH

Checking and adjusting the backlash of final drive

- Tighten the setscrew **B** (Tool Bulletin no. 102/2) into the drain plug boss so as to lock the ring gear;

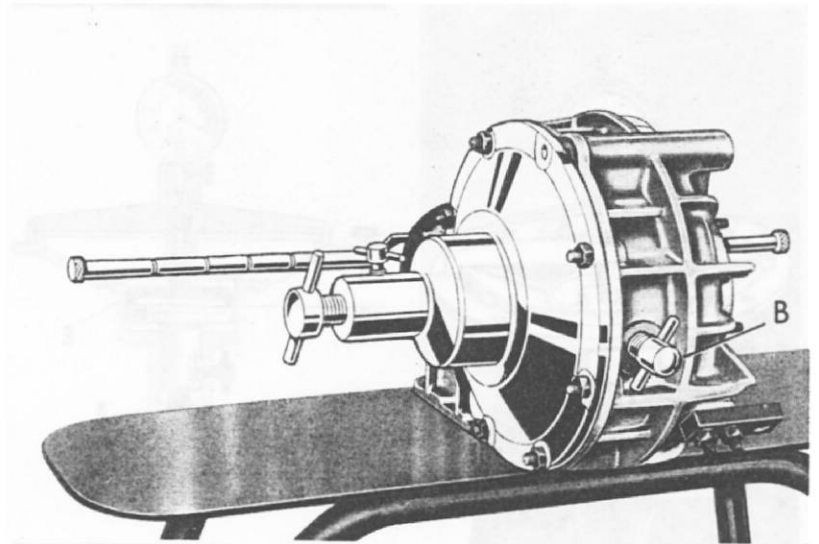

- have the sensing needle of a dial indicator resting against the centre plate of tool **C.5.0100** (Tool Bulletin no. 20/1) in correspondence of the reference mark 45 mm apart from pinion center line;
- swing the tool in both directions and take readings of backlash on dial indicator:
specified value: .15-.25 mm (.006-.009")
 This corresponds to an actual backlash at the final drive teeth of **.05-.10 mm (.002-.004")**.

Note: the backlash shall be checked in four different positions of the ring gear; to do this, rotate the pinion of a complete turn after each check and lock the ring gear against rotation by setscrew **B**.

- If the backlash is not as prescribed, adjust as follows:
 - remove the tool **C.6.0115** from differential carrier and take out the differential case;
 - change shims as required between R.H. bearing cup and seat, bearing in mind that:
 - removing shims decreases the backlash;
 - adding shims increases the backlash.
- Reassemble the R.H. bearing cup and shims **S** as per above procedure to the differential carrier with the tool **A.3.0208**.
- Reinstall the differential case and the tool **C.6.0115** in place of the L.H. axle tube.
- Adjust screw **A** of tool **C.6.0115** so as to obtain the specified bearing pre-load: check the total pinion & ring gear bearing pre-load and check for the correct backlash. Repeat the adjustment procedure, if necessary.

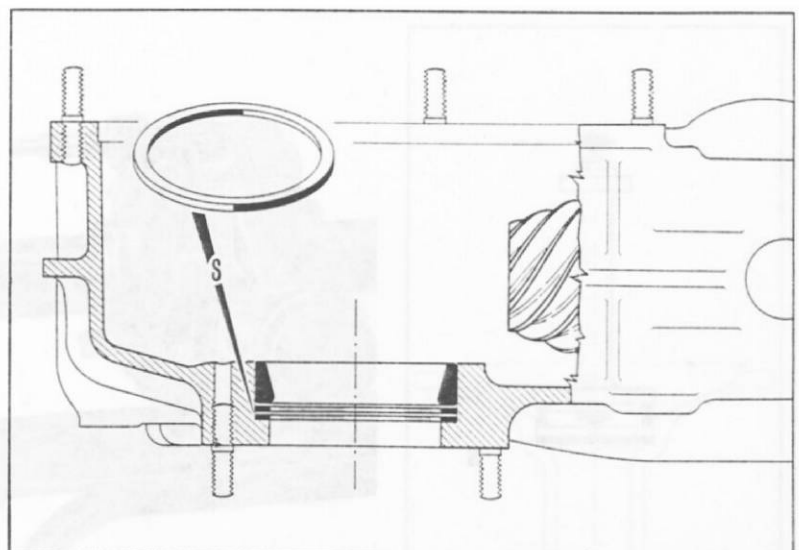
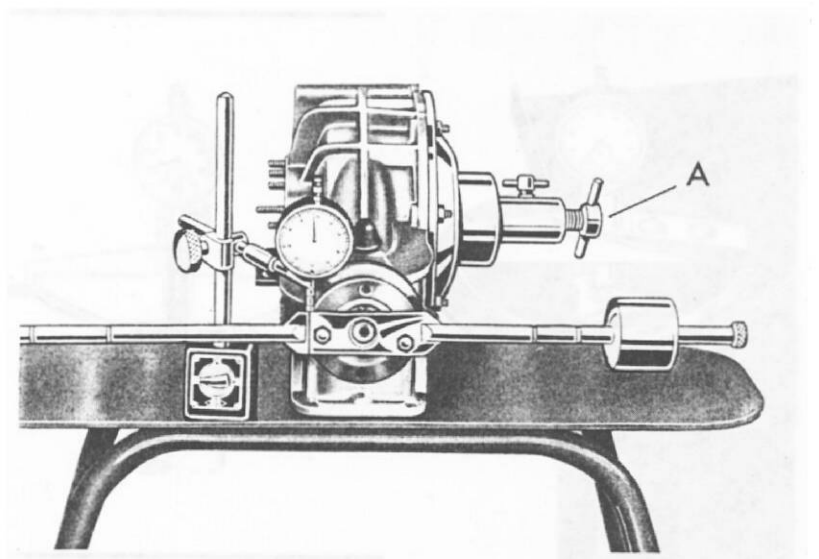

REASSEMBLY ON BENCH

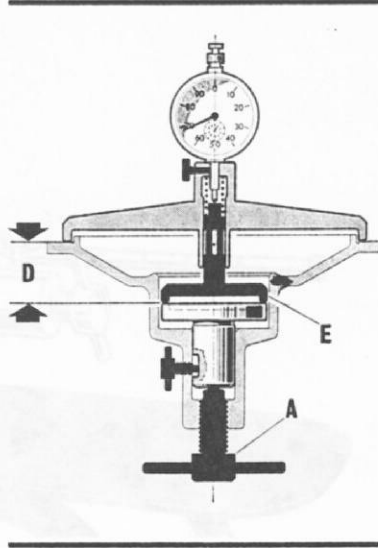
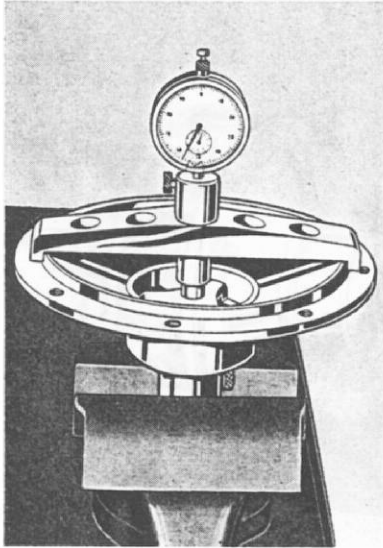

Reassembling the differential

- After the pre-load and backlash are set as specified, it is necessary to determine the thickness of shims between L.H. bearing cup and its seat. Proceed as follows:
 - remove tool C.6.0115 from differential carrier;
 - withdraw the bearing cup previously fitted and, without disturbing the screw A, record the dimension D with a dial indicator and the tool E (C.6.0102) as shown;

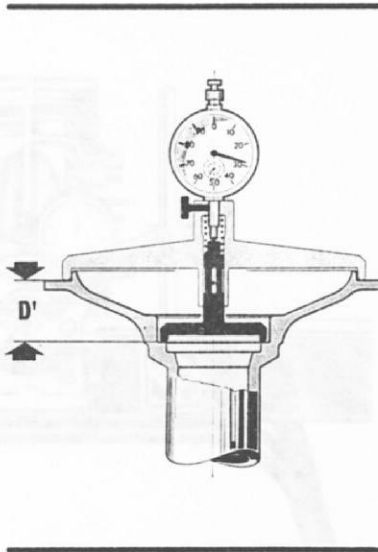
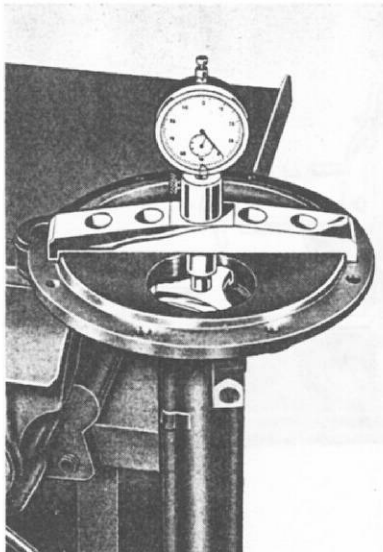

- take a reading of dimension D' in the L.H. axle tube.

The difference $D - D'$, diminished by .05 mm (.002"), will give the thickness of shims to be inserted between bearing cup and the seat in the axle tube.

Note: the reason for decreasing the thickness of shims by .05 mm (.002") lies in the fact that, while the bearing cup makes a loose fit in tool during the measurement, in the axle tube the cup makes a press fit; as a consequence, the cup shrinks radially causing a reduction in pinion-to-ring gear clearance which eventually results in a greater bearing pre-load.

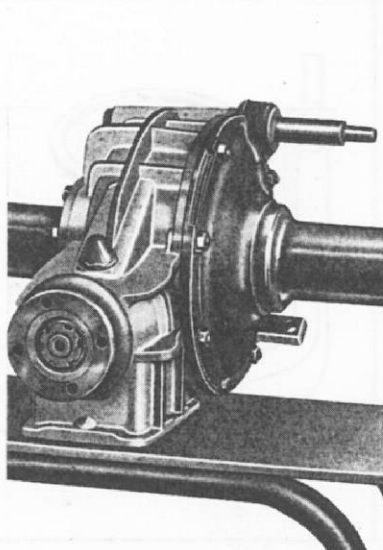
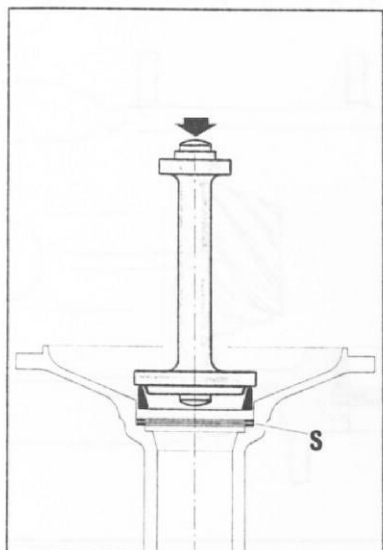

- Install shims S of thickness as previously determined within bearing seat in L.H. axle tube; then drive the bearing cup in place with tool A.3.0208.
- Assemble the R.H. & L.H. axle shaft and fasten with the attaching nuts; **do not bend the tabs of tabwashers.**
- Again check the backlash and the pre-load of differential case bearings:
 - if the pre-load is as specified and the backlash lower than normal, add shims at the R.H. bearing and remove the same thickness from the pack of shims at the L.H. bearing; vice-versa if the backlash is greater than normal;
 - if the backlash is as specified and the pre-load is wrong, add or remove the same quantity of shims from both bearings according to whether the pre-load must be increased or diminished respectively.

REASSEMBLY ON BENCH - REINSTALLATION

- Bend the tabs of tabwashers of nuts attaching axle tubes to differential carrier.
- Remove the pinion shaft flange and drive the oil seal packing on pinion shaft with tool **A.3.0167**; reassemble the flange and tighten the ring nut to **8-14 Kgm** (58-101.2 lb-ft) with a torque wrench and the bushing **A.5.0104**; counteract flange rotation with tool **A.2.0144**.

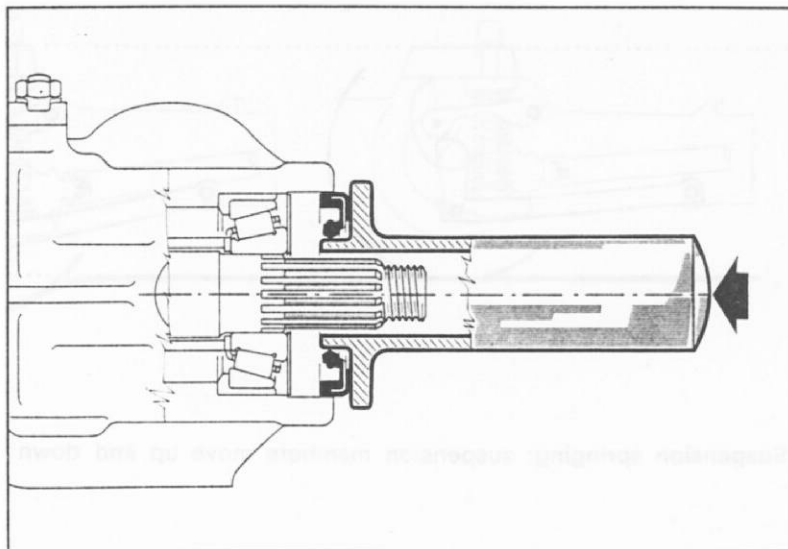

- If previously removed, drive the bearing on to axle shaft with tool **A.3.0109**; tighten the ring nut with the wrench **A.5.0120**.
- Insert the axle shaft into the tube and drive it into the differential side gear splines.
- Complete the reassembly as directed on page 16.
- Install the rear axle assembly to the body by reversing the removal procedure.

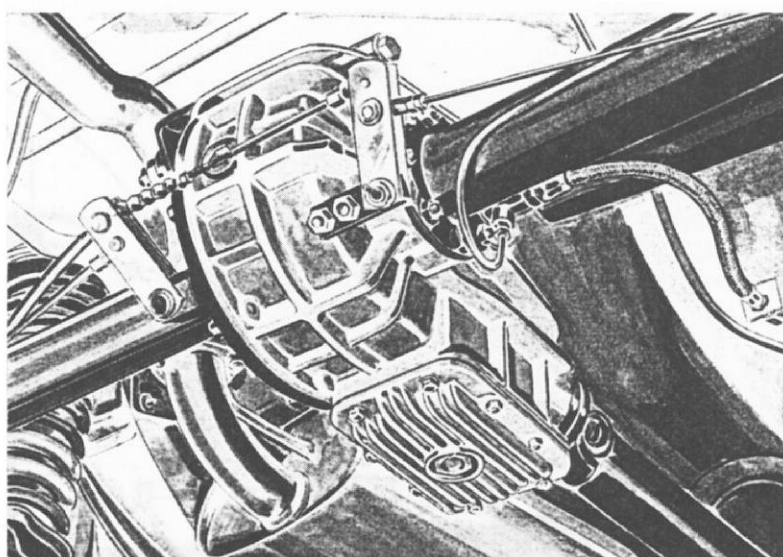

TIGHTENING TORQUE SPECIFICATION

	Kgm	lb - ft
Screws securing ring gear to differential case	4.5 - 5	32.6 - 36.1
Ring nut securing flange to final drive pinion	8 - 14	58 - 101.2
Nuts securing bearing housing to rear axle tubes	4.8 - 5.5	34.8 - 39.7
Nuts securing radius rods to body	10 - 11.5	72 - 94
Nuts securing radius rods to rear axle tubes	11.5 - 13	83 - 94
Nut securing reaction trunnion to body	4.8 - 5.5	34.8 - 39.7
Nut securing reaction trunnion to differential carrier	11 - 15	79.6 - 108.5
Screws securing brake cylinders to axle tubes (Dunlop brakes)	.4 - .5	2.9 - 3.6
Screws securing rear brake caliper to support { Dunlop brakes	2.3 - 2.8	16.7 - 20.2
ATE brakes	5.5 - 6.5	39.8 - 47.0
Nuts securing wheels	6 - 8	43.4 - 57.8
Bolts joining differential flange to propeller shaft yoke	3.5 - 4	25.3 - 28.9

REAR SUSPENSION

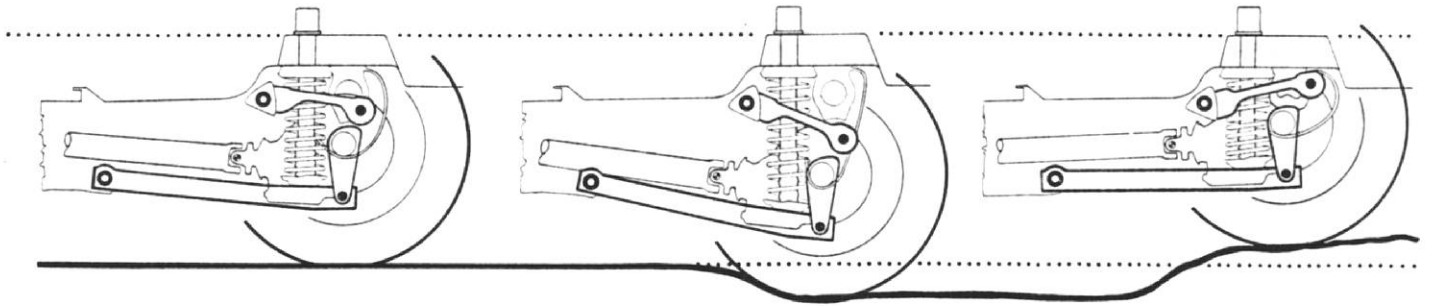

Suspension springing: suspension members move up and down while the car remains level.

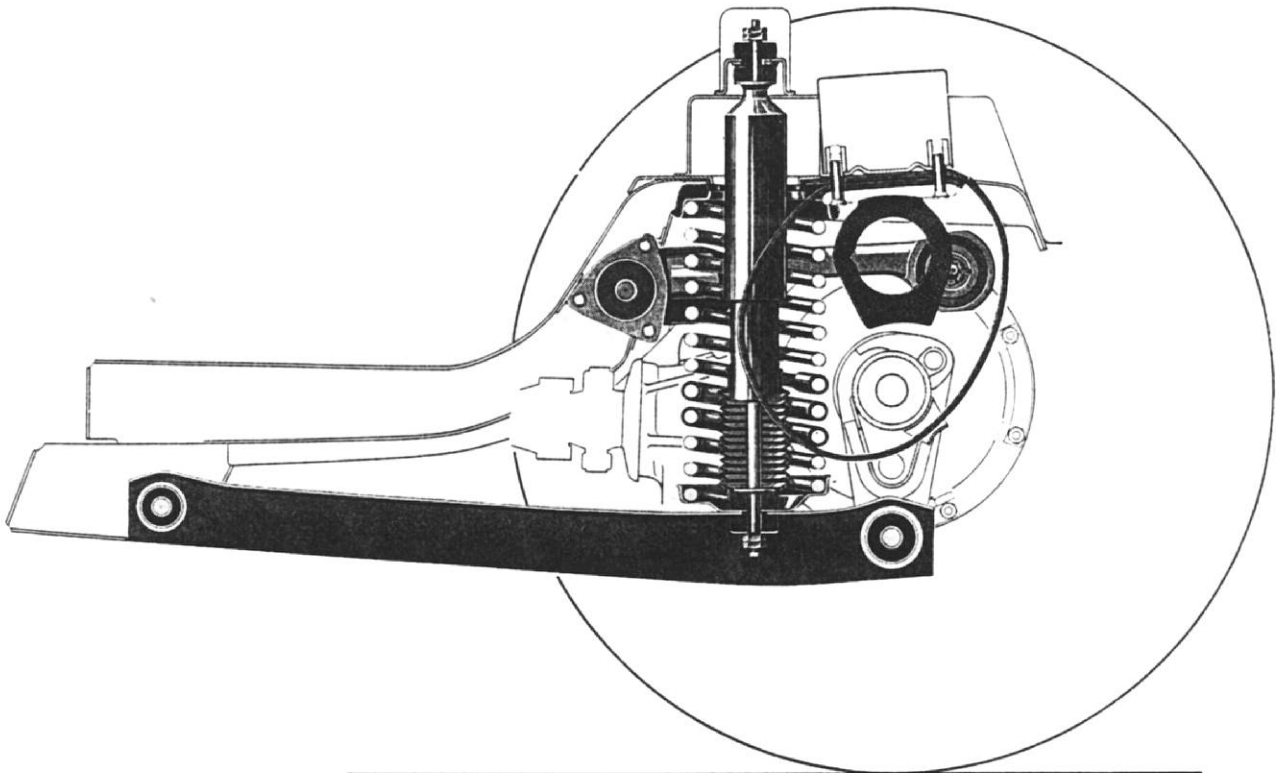

The rear suspension consists of coil springs and large diameter telescopic shock absorbers coaxial with the springs. The upward movement of the rear axle is limited by a rubber pad and the rebound by a fabric and rubber strap.

REAR SUSPENSION

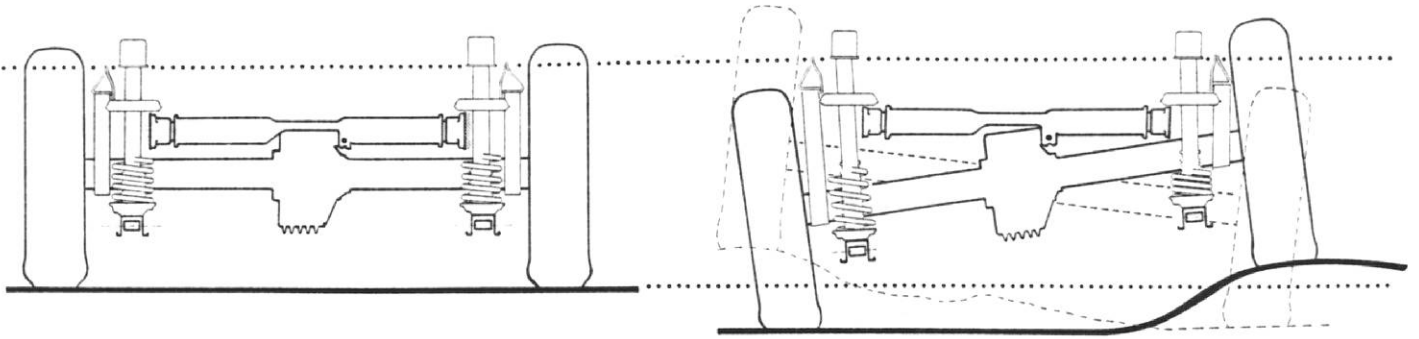

Suspension tilting: the rear axle pivots on the reaction trunnion fixed to the body while the car remains level.

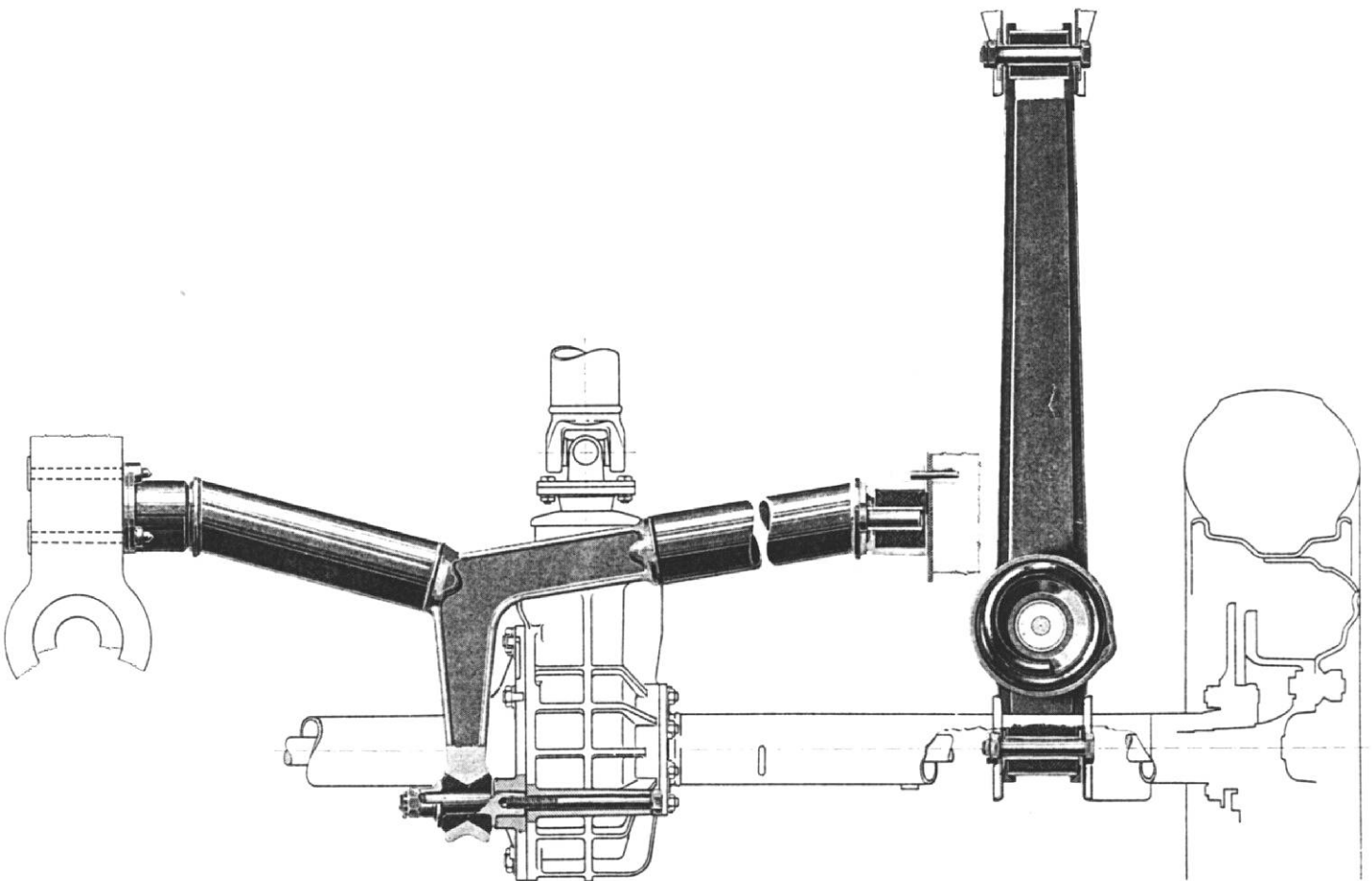

PADS & REBOUND STRAPS - SHOCK ABSORBERS

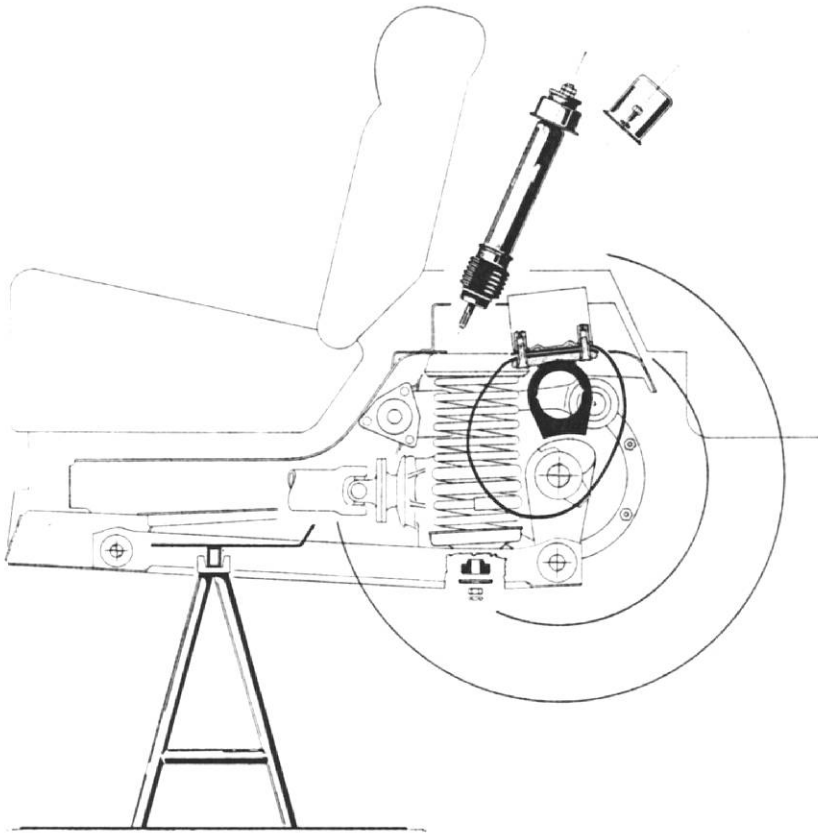

Removal of rebound straps and rubber pads

- Load the rear end of car so as to slacken the rebound straps slightly.
- Remove screws attaching rebound straps and pads.
- Replace defective parts.

Note: when reassembling pads and rebound straps make sure they are in the same position as before removal.

Removal of shock absorbers

- Disconnect the shock absorbers from radius rods.
- Fully collapse the shock absorbers.
- From the luggage compartment remove the shock upper attachments and withdraw the shocks upward; to do this easily take away the rear seat backrest.

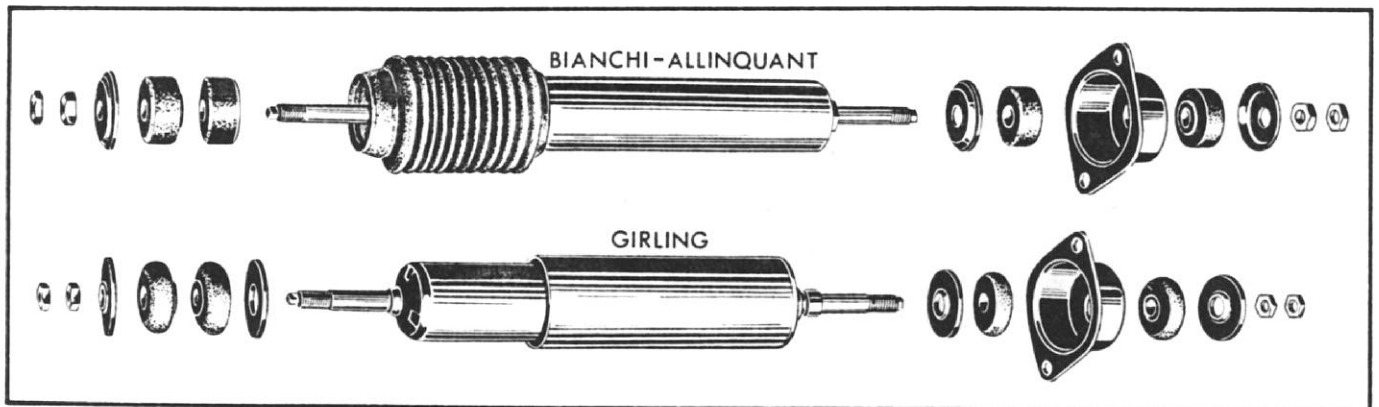

Shock absorber inspection and testing

- Inspect the shock absorber barrel and the cover for distortion.
- Check the cover for binding against the shock absorber barrel and for any sign of oil leaks.
- Check that shock absorber mounting pads are in good condition and replace if necessary.
- Check the shock absorbers on the test rig for correct damping action at high and low speed.

SHOCK ABSORBERS

- Test as directed in Tool Bulletin no. 32/1 and specifically:
 - draw the zero reference line with the rig under no load;
 - install the shock absorber to be tested on the rig;
 - turn the control knob to slow speed and start the rig motor: the writing needle will record the corresponding curve;
 - then turn to high speed and record the curve.

The readings should fall within the limits given in the table below.

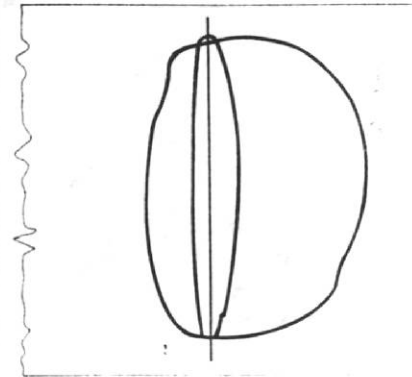
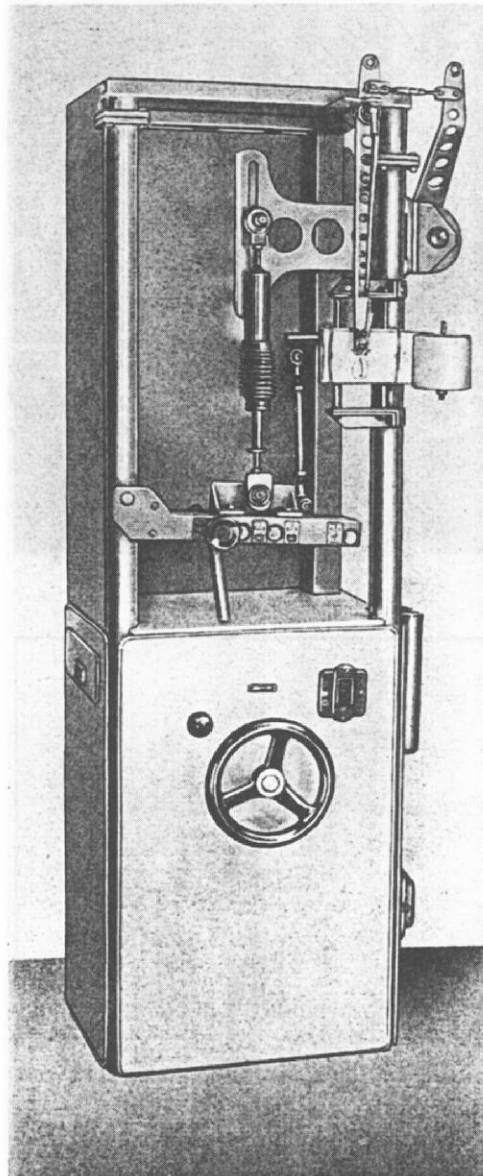

Rear shock absorber rating:

MAKE	EXTENSION		COMPRESSION	
	High speed	Low speed	High speed	Low speed
Bianchi	135-190 Kg	19- 55 Kg	50- 80 Kg	9-22 Kg
Allinquant	300-418 lbs	41-121 lbs	110-176 lbs	20-48 lbs
Girling	121-190 Kg	13- 32 Kg	27- 42 Kg	9-18 Kg
	270-418 lbs	29- 70 lbs	60- 92 lbs	20-39 lbs

Note: shock absorbers must be tested when cool. In the event the shock has been left inactive for a long time, cycle it through a few strokes before testing.

Replace shocks with new ones if test results do not fall within the above limits.

Reinstall the shock absorbers by reversing the order of removal. Inspect the mounting pads and replace, if necessary.

Take readings with the suitable transparent chart (the chart shown is rated in Kgs).

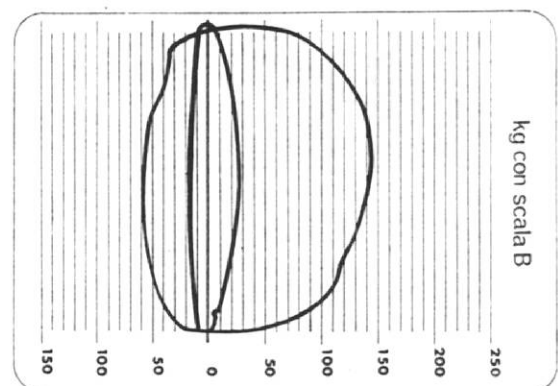

REACTION TRUNNION

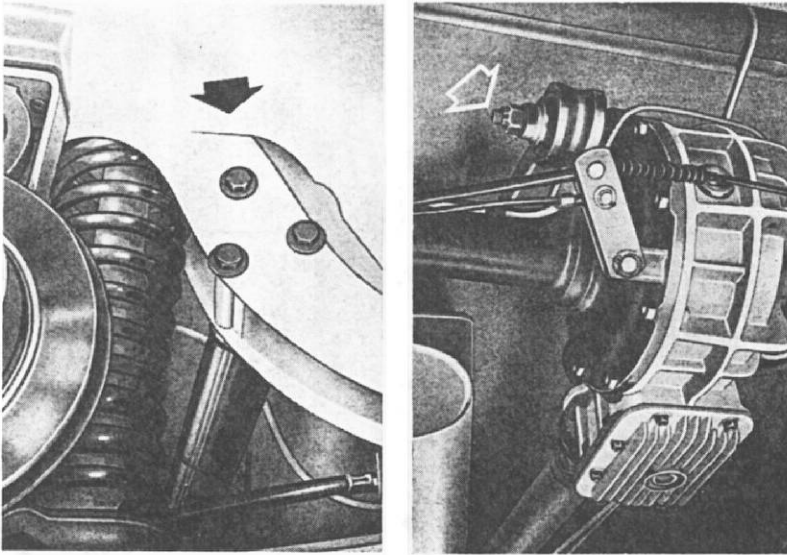

Removal of reaction trunnion from car

- Remove the rear section of the exhaust pipe;
- loosen the screws attaching the trunnion rubber bushing seats to the body;
- unscrew the nut attaching the trunnion to the pin on rear axle;
- swing down the trunnion and take it away.

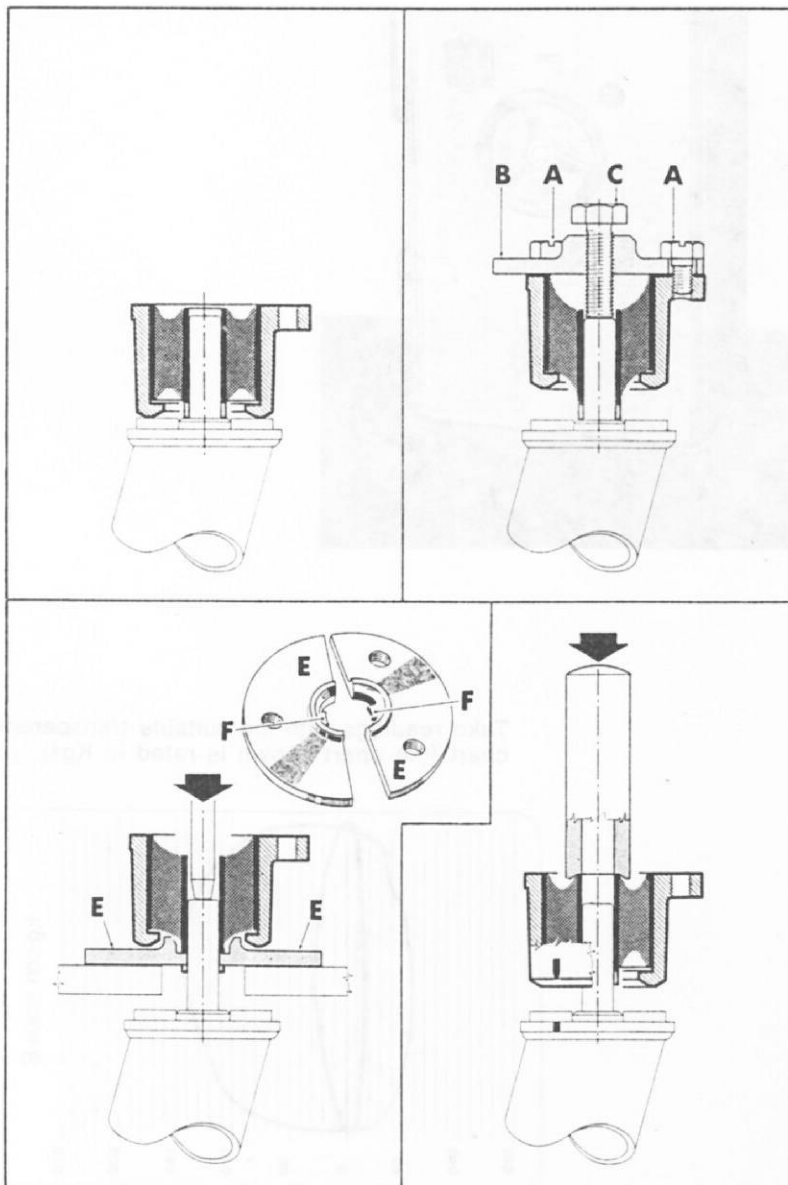

Inspection and replacement

- Check the pads for the attachment of trunnion to rear axle for any sign of deterioration; replace, if necessary.
- Check the rubber bushings and their seats for good condition. If necessary, replace them as follows:
 - secure the flange **B** of the tool **A.3.0163** (Tool Bulletin no. 101) to the rubber bushing seat with the three screws **A**; tighten screw **C** so as to stretch the rubber until enough gap is left to insert the half-plates **E**;
 - when inserting the half-plates take care to match the tabs **F** with slots in the inner sleeve of rubber bushing; then, slacken screw **C**;
 - remove the flange **B** and pull the bushing and the seat out as a unit by using a suitable punch.

To reinstall the rubber bushings on trunnion align the reference marks on bushing seat and trunnion and drive the bushing with tool **A.3.0164**.

REACTION TRUNNION - SUSPENSION SPRINGS

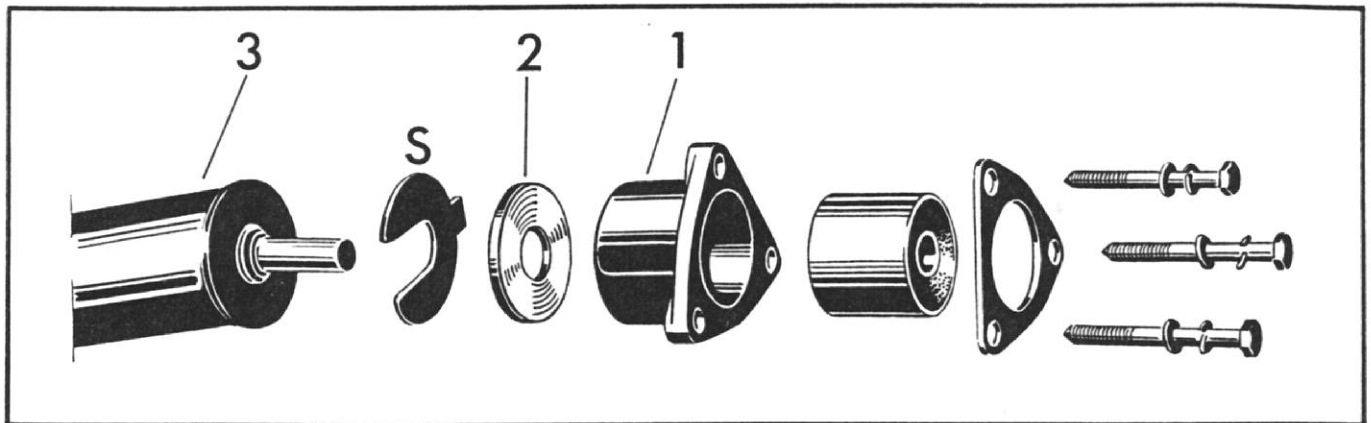

Reinstalling the reaction trunnion

- Proceed in reverse order of removal. On reinstallation check that total gap **L** (right side + left side) between rubber bushing seat **1** and the plastic washers **2** does not exceed **1 mm (.04")**; if necessary, add shims **S** between the trunnion beam **3** and the plastic washer; then electric weld such a shim to the trunnion. When selecting the thickness of shims to be added, keep in mind that a maximum interference fit of **1 mm (.04")** is allowed between reaction trunnion and body.
- Tighten with a torque wrench:
 - the screws attaching reaction trunnion to body to **4.8 - 5.5 Kgm (34.8 - 39.7 lb-ft)**;
 - the nut securing reaction trunnion to rear axle to **11 - 15 Kgm (79.6 - 108.5 lb-ft)**.

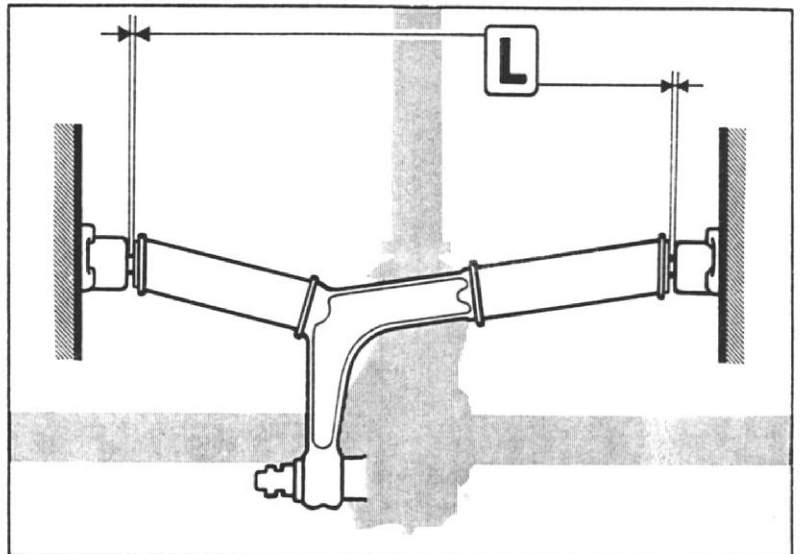

Suspension springs

- Remove the springs with tool **A.2.0143** as directed on page 17.
- Check the springs against the specifications given in the table and for any sign of distortion.

STATIC TEST					
	LENGTH		Test load	Color mark	
	Free	Under test load			
GIULIA	1300	449 mm 17.7"	↑	321 -341 Kg 706 -750 lbs	Blue Blue
	1300 ti Super				
	ti	461 mm 18.3"		341.5-362.5 Kg 752 -798 lbs	—
	ti Super	405 mm 15.9"	252 mm 9.9"	245.4-260.6 Kg 540 -574 lbs	Blue Blue
	Sprint GT GTC	429 mm 16.9"		265 Kg 584 lbs	White-White White-Blue
	Sprint GT Veloce	437 mm 17.2"		268.7-285.3 Kg 592 -627 lbs	Blue-Blue White-Blue
Spider 1600	429 mm 16.9"		↓	257 -273 Kg 566 -600 lbs	White-White White-Blue

RADIUS RODS

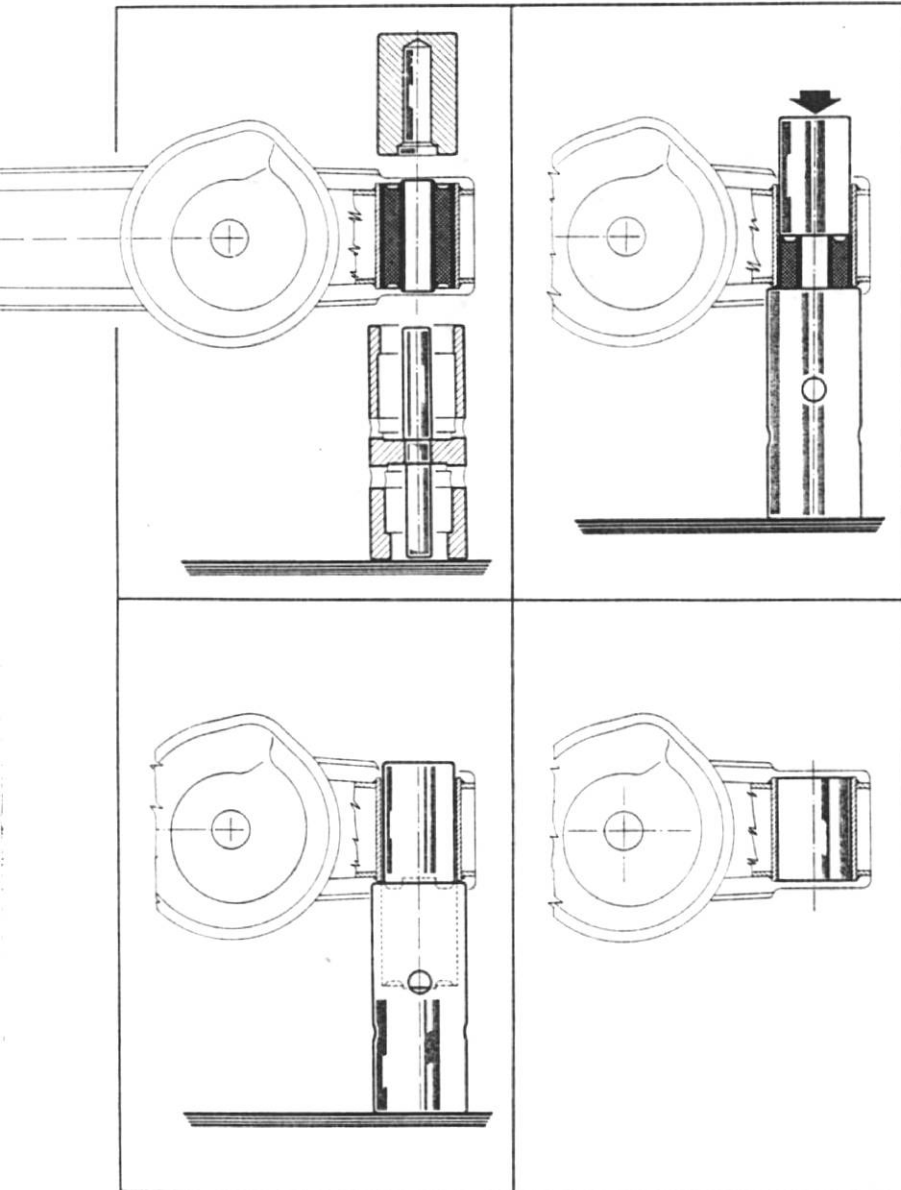

Removing the radius rods

- Take the spring away from the radius rod to be removed with the tool **A.2.0143** as directed on page 17.
- Withdraw the bolt connecting radius rod to body and remove the rod.

Inspection and replacement

- Check the front and rear rubber bushings of the radius rod for any sign of damage to the rubber.
- If damaged, remove the rubber bushing with the tool **A.3.0211** (see figure).

- Insert the new rubber bushing with tool **A.3.0211**.
- Reinstall the radius rod onto the car in reverse order of removal.
- Tighten with a torque wrench:
 - the nuts securing radius rods to rear axle to **11.5-13 Kgm** (83-94 lb-ft);
 - the nuts securing radius rods to body to **10-11.5 Kgm** (72-33 lb-ft).

WARNING

On completion of suspension assembly check the car for correct alignment. **To carry out this check disconnect the shock absorbers and stabilizer rod and put the car under static load.**

The dimension **C** between axle tube and rubber buffer must be as specified in the table below. If necessary add shims in **2** as required and remove seat **3**.

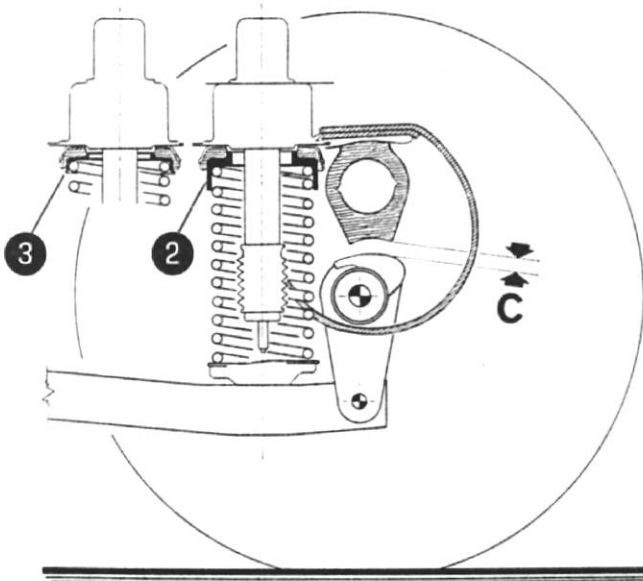

C	Model
10 ± 5 mm .2/.6"	Giulia 1300, Giulia 1300 ti, Giulia TI, Giulia Super
20 ± 5 mm .6/1.0"	Giulia TI Super
15 ± 5 mm .4/.8"	Giulia Sprint GT, Giulia Sprint GT Vel.
12 ± 5 mm .3/.7"	Giulia GTC
33 ± 5 mm 1.1/1.5"	Spider 1600

ALFA ROMEO - Via Gattamelata, 45 - 20149 MILANO
Diass - Pubblic. 1222 - R2 - 12/68 (1200)



Alfa Romeo