

■ GIULIA SUPER ■ 1750 BERLINA ■ 1750 GT VELOCE ■ 1750 SPIDER VELOCE ■

ELECTRICAL UNITS: CHARGING SYSTEM ■
BOSCH K1 (RL) 14V 35A 20 ALTERNATOR ■

Alfa Romeo

SHOP MANUAL



CONTENTS

CHARGING CIRCUIT

- 2 Wiring diagram
- 3 Regulator operating principles
- 4 In-car test

ALTERNATOR

- 5 Description
- 6 Preparatory steps for testing diodes
- 9 Testing diodes with a test lamp
- 10 Testing diodes with an ohmmeter
- 12 Testing diodes with a special diode tester
- 14 Testing on bench

DISASSEMBLY & OVERHAUL

- 16 Special tools for replacing diodes
- 18 Pulley – Brush holder – End frame
- 19 Rotor - Ball bearing
- 20 Replacing diodes
- 22 Inspection and testing
- 24 Replacing one positive or negative diode

REASSEMBLY

- 25 Drive end frame
- 26 Brush – Negative diode heat sink
- 27 Positive diode heat sink
- 28 Connections
- 29 Rotor – Brush holder
- 30 Press-fit field diodes

31 SPECIFICATION



This Manual, supplied to all authorised ALFA ROMEO Repair Shops, contains instructions for the overhaul and reconditioning of the BOSCH K1 (RL) 14V 35A20 alternator.

The operations are amply illustrated so that the detail and unit concerned can be quickly identified and the tools to be used and the correct method of operation can be seen.

Only genuine spares should be used if any assemblies or parts have to be replaced; only in this way can complete interchangeability and fully satisfactory performance be guaranteed.

This Manual should be kept continuously up-to-date by the addition of new information and instructions issued at intervals by the Technical Service Division in the regular Information Sheets.

ALFA ROMEO
Direzione Assistenza

CHARGING CIRCUIT

WIRING DIAGRAM

The charging circuit consists of:

- Alternator BOSCH K1 (RL) 14V 35A 20
- Voltage regulator BOSCH AD 1/14 V
- Warning Light

The wiring diagram of the charging circuit is as shown below.

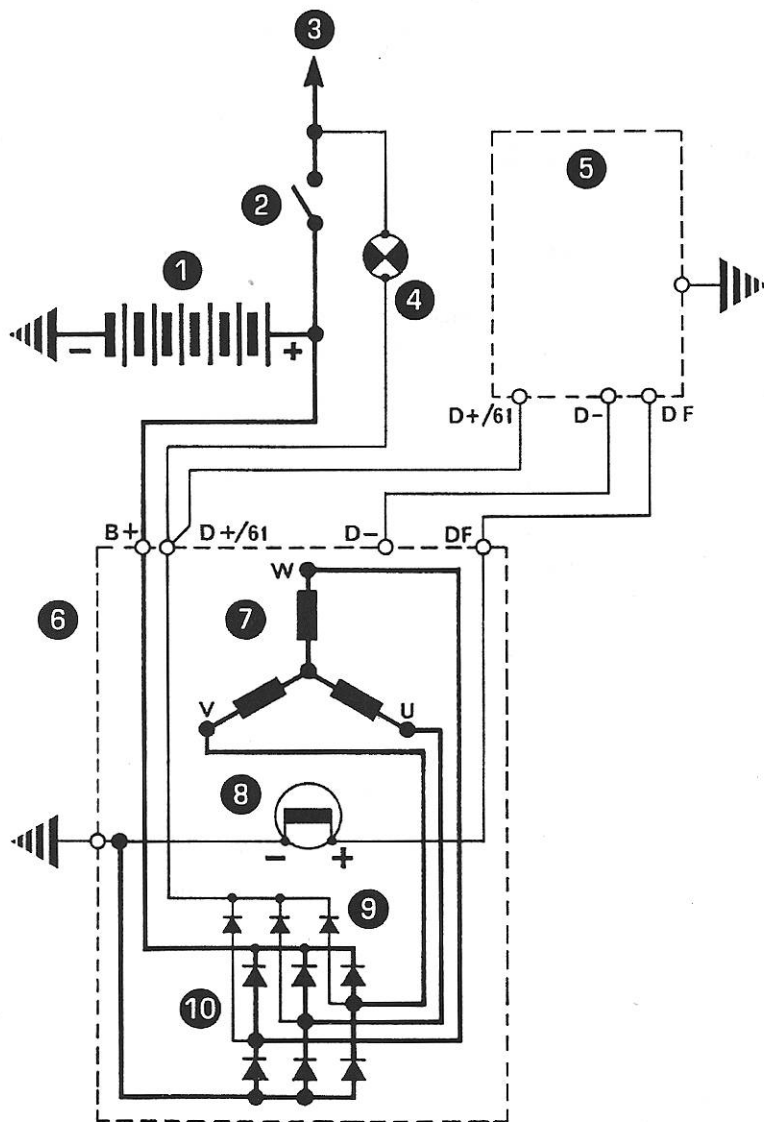

- 1 Battery
- 2 Switch
- 3 To accessory circuits
- 4 Warning light
- 5 Regulator
- 6 Alternator
- 7 Stator winding
- 8 Field winding
- 9 Field current diode rectifier
- 10 Output current diode rectifier.

D+/61 field rectifier terminal: connected to regulator terminal D+/61 and to warning light.

DF field input terminal: connected to regulator terminal DF.

B+ battery terminal.

D- ground terminal: connected to regulator terminal D-.

REGULATOR OPERATING PRINCIPLES

CONSTRUCTION

The alternator output is regulated by a resistance inserted in the alternator field circuit by the regulator.

Such a resistance is connected across the regulator terminals D+ and DF. The armature is under the tension of a spring which holds the points together for contact with the terminal D+ until it is overcome by the magnetism of the regulator winding parallel connected to the alternator terminals D+ and D-.

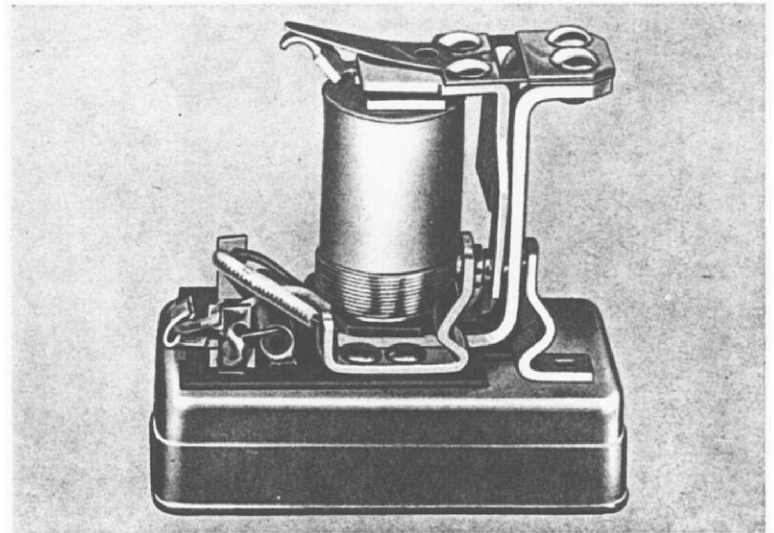

OPERATION

When the alternator starts, the output voltage is lower or barely attains 12 volts. Thus, full current flows from terminal D+ through armature points to the alternator field winding (DF).

As the alternator output increases the magnetism in the regulator winding also increases. When the voltage for which the regulator is set (about 13.8 volts) has been reached, the armature is pulled toward the core and the D+ points separate.

The current bypasses the air gap between points and, flowing through the resistance in the alternator field circuit (a small part also flows back through the armature which is grounded via the other sets of points now closed) causes the alternator output to drop. As a consequence, the magnetic strength in the winding core also drops thus permitting the armature spring to pull the armature away from the core and the D+ points to close again. The entire sequence is repeated more or less rapidly according to the alternator RPM.

The regulator is factory set; therefore, if any trouble is experienced, do not attempt to repair the regulator but replace it with a new one.

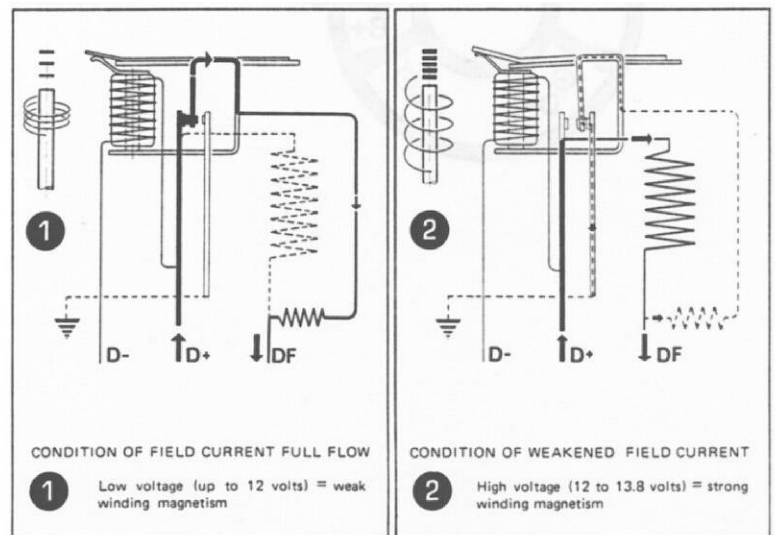

CHARGING CIRCUIT

IN-CAR TEST

When the warning light or whatever else indicates that the charging system is developing troubles, a test should be made.

An in-car inspection can be performed after the engine has been stopped and left cool down to gain a safe access to the alternator. Cautiously disconnect the terminal B+ and connect an ammeter and a voltmeter as shown.

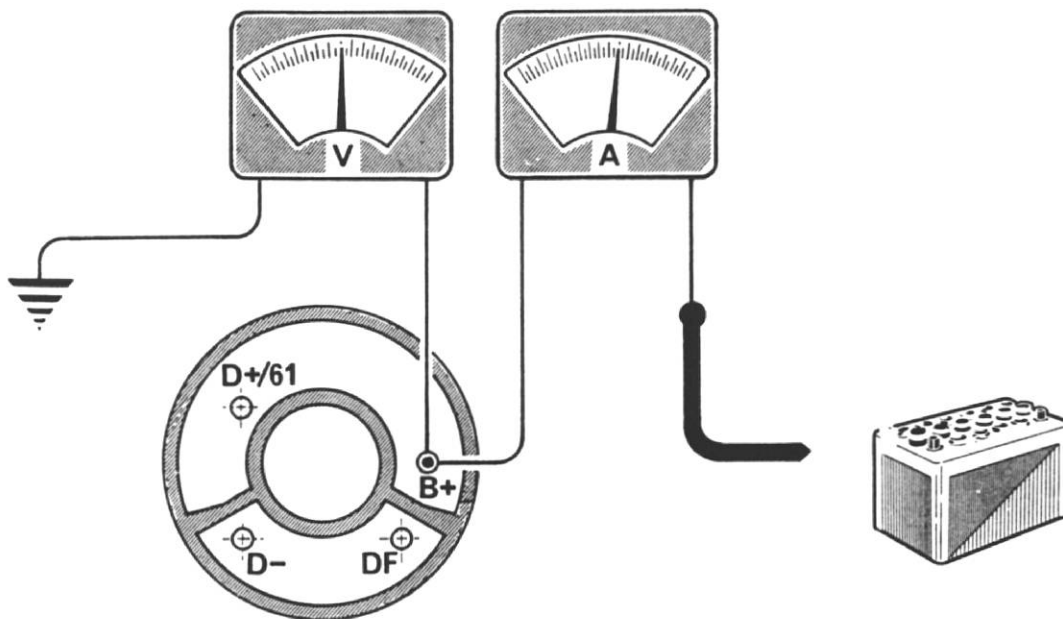

Start the engine.

Switch on some of the lines, e.g. the headlamp, then check charging current and voltage.

If the readings are 20 to 30 amps and 12 to 13 volts the alternator is operating properly and the trouble is somewhere else.

Check the connections carefully; inspect with special care the warning light circuit and the leads to the regulator.

Should the trouble persists even after faulty connections have been remedied, the alternator must be disassembled and thoroughly tested on a suitable tester.

ALTERNATOR DESCRIPTION

The alternator is of the three phase, twelve pole type, with fan ventilation and a six diode rectifier.

Each phase winding of the stator is connected to one field diode whose output is in turn connected to the terminal D+/61 (refer to the diagram on page 2).

The six diode rectifier hook up is such that three diodes have positive polarity and the other three have negative polarity.

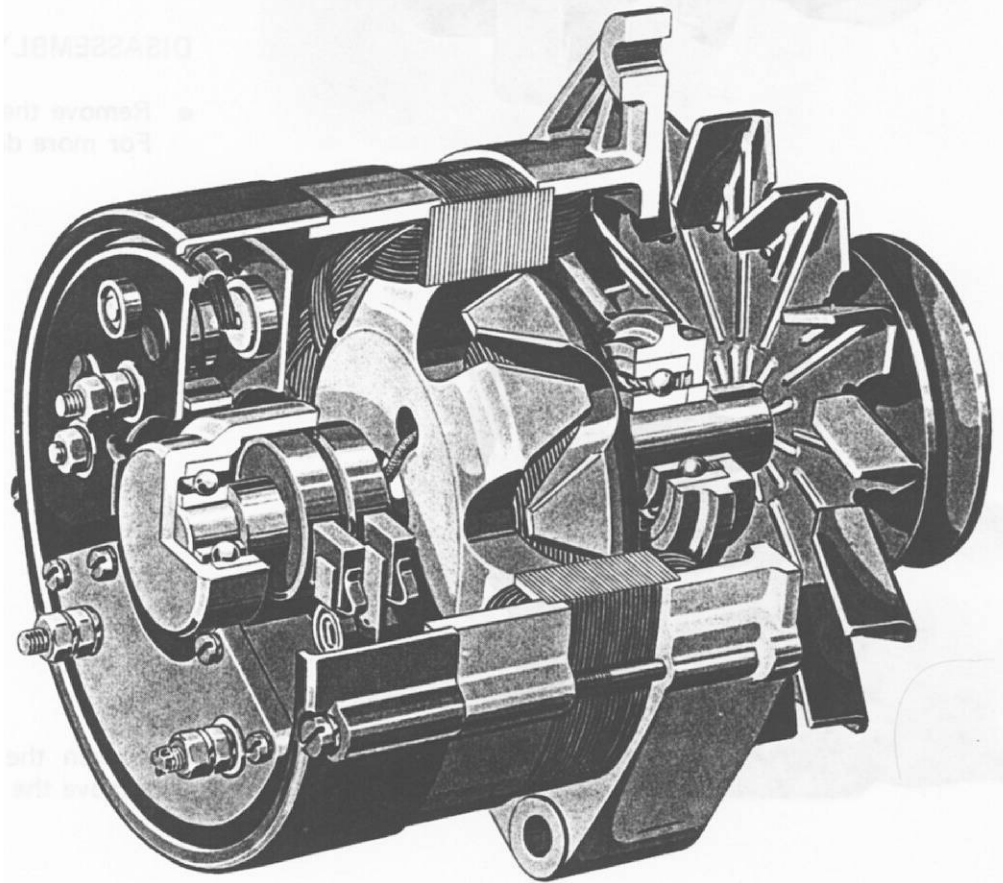

The positive diode heat sink is insulated from ground while the negative heat sink is grounded.

Between the two heat sinks there is the bracket of the three field diodes properly insulated from the alternator frame.

The stator windings are "Y" connected.

The field winding is wound on the mounting core between the rotor segments with twelve magnetic poles.

The field winding is excited through the slip rings.

ALTERNATOR

PREPARATORY STEPS FOR TESTING DIODES

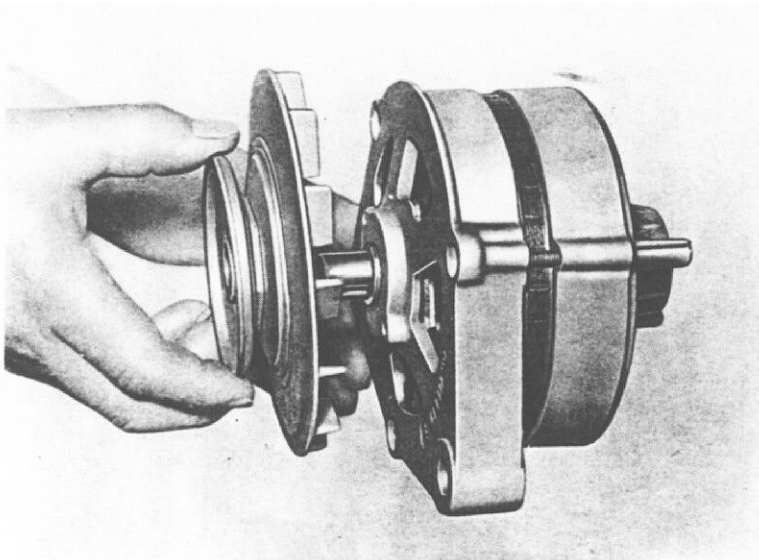

REMOVAL FROM CAR

- Disconnect the battery by detaching the negative terminal first to prevent possible shorts which may damage the diodes.
- Take the drive belt away and remove the alternator.
- Place the alternator on a clean bench.

DISASSEMBLY FOR TESTING DIODES

- Remove the drive pulley.
For more details refer to page 18.



- Loosen the three attaching screws and remove the plastic ring.

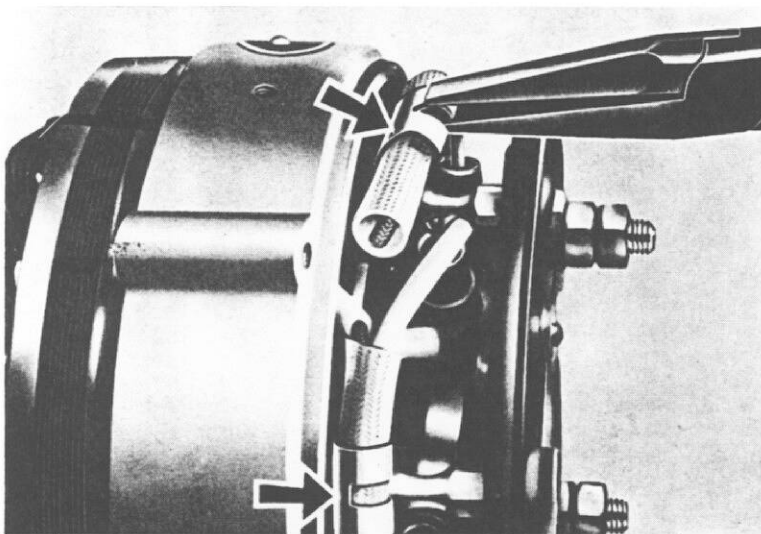

- Free the leads from clips with pliers. Spread apart the leads so that they can then be easily disconnected.

PREPARATORY STEPS FOR TESTING DIODES

- Disconnect the three clusters of four leads by unsoldering or cutting them as shown.
- Withdraw and retain the insulating sheaths.

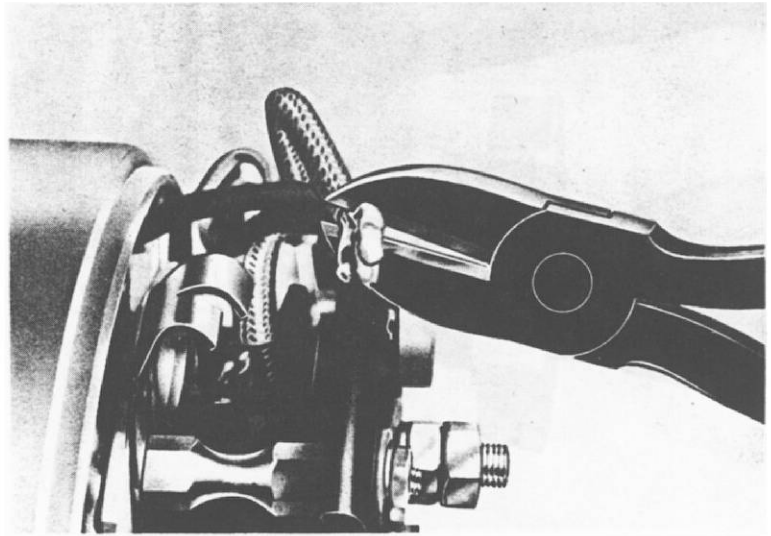

- Remove the positive diode heat sink complete with the field diode bracket.

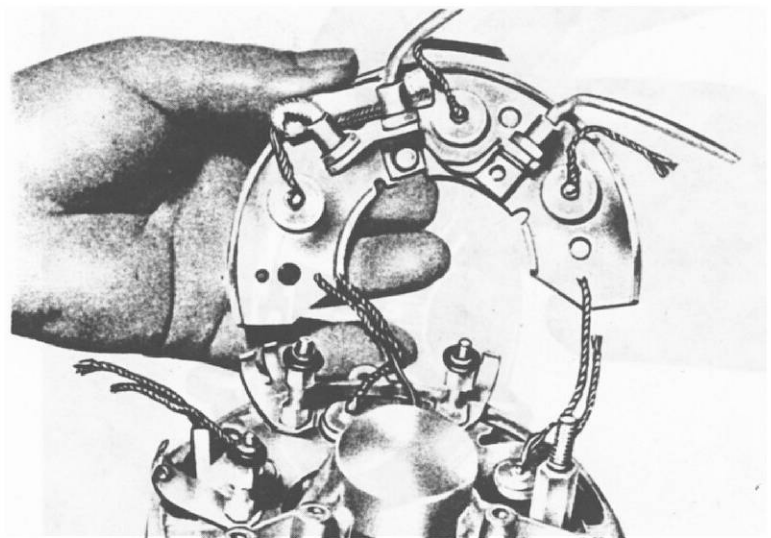

- Unscrew the spacers between the heat sinks and loosen the through bolts.

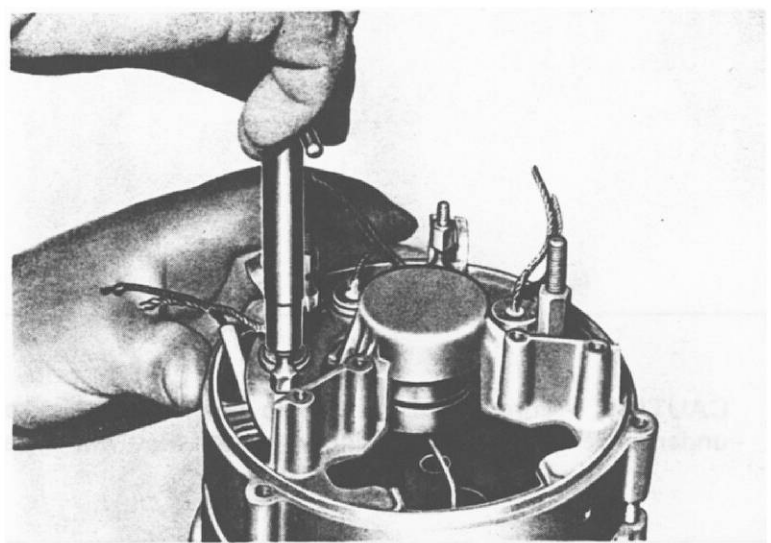

ALTERNATOR

PREPARATORY STEPS FOR TESTING DIODES

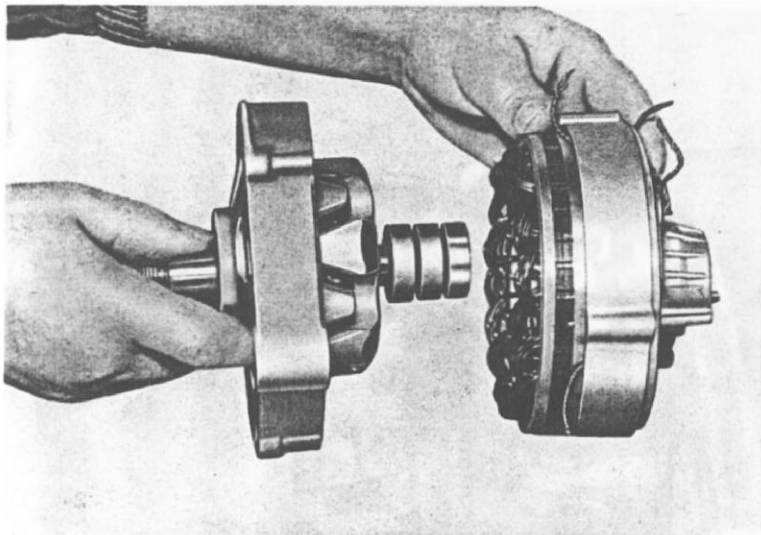

- Ease the rotor out of the stator frame.

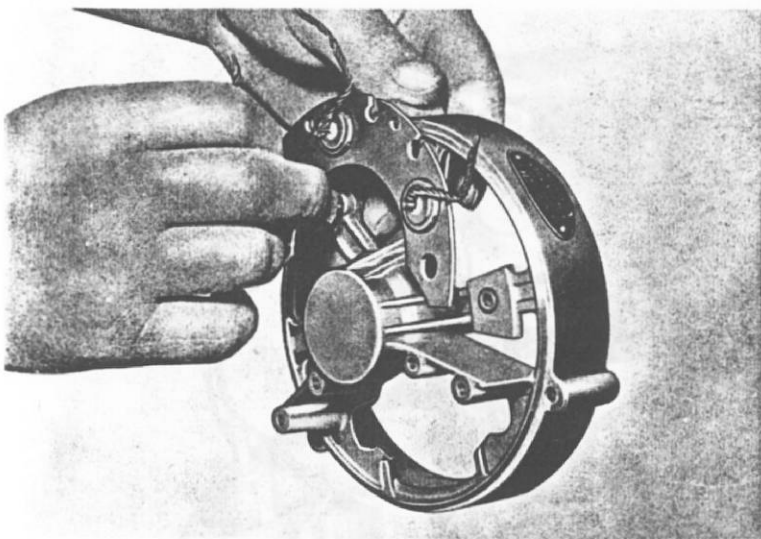

- Remove the negative diode heat sink. At this stage each diode can be tested separately.

CAUTION – Throughout testing do not keep diodes, especially when out of their heat sink, under current load for too long a time or they will suffer from overheating.

TESTING DIODES WITH A TEST LAMP

TESTING A POSITIVE DIODE

Connect a 2 watt/12 volt test lamp across battery and positive diodes as shown. If diodes test good the lamp should light up in one direction and not in the other. If the lamp fails to go on in both directions the diode is open circuited. If the lamp goes on in both directions the diode is short circuited.

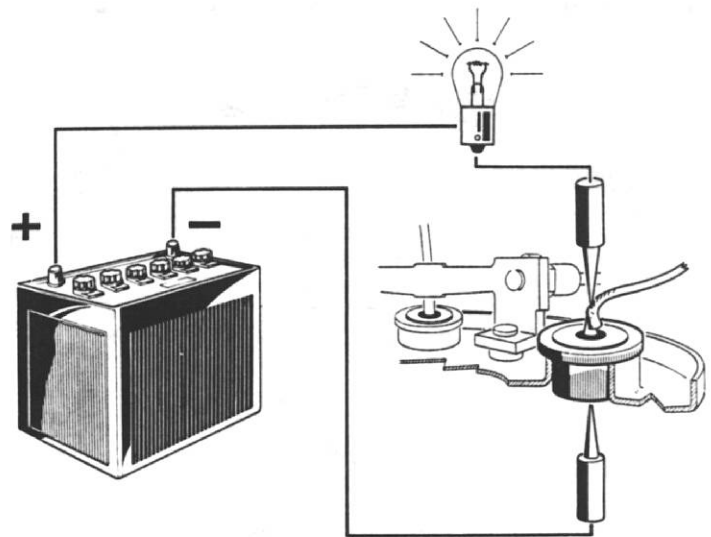

TESTING A NEGATIVE DIODE

Make the connections as shown and perform the test as outlined above.

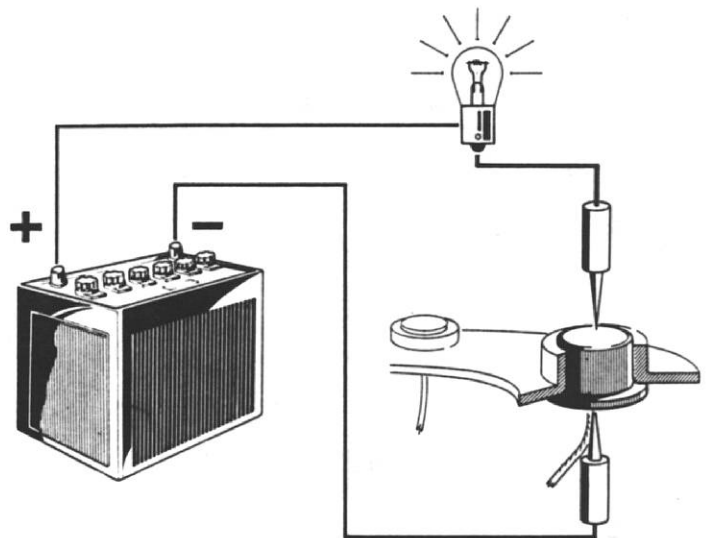

TESTING A FIELD DIODE

Make the connections as shown and perform the test the same way as for positive diodes.

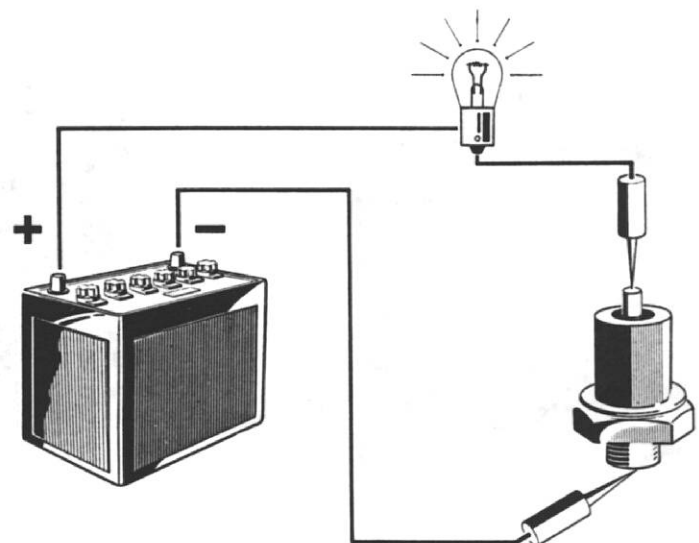

TESTING DIODES WITH AN OHMMETER

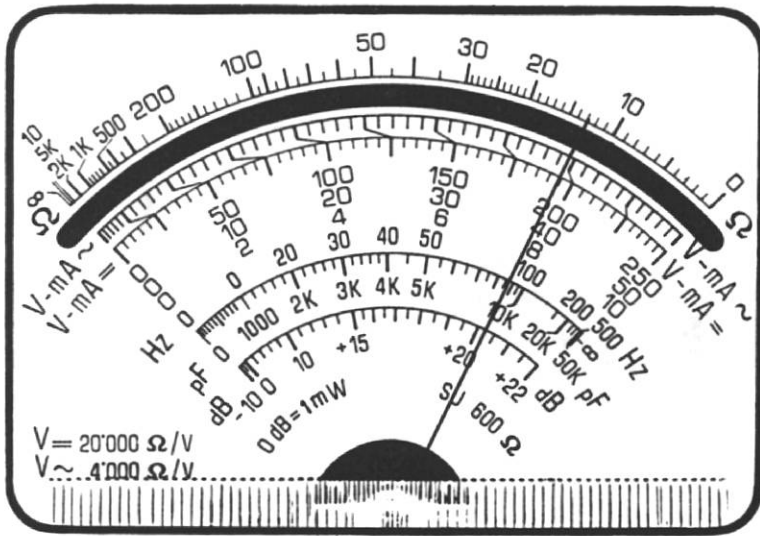

NOTE. For diode testing no exact reading is specified depending it upon the scale and the calibration of the ohmmeter.

Usually, an efficient diode will show a reading of some ohms in the flow-through direction and some kilo-ohms in the no-flow direction.

The purpose of the instrument is essentially to indicate whether the diode allows the current to flow in the proper direction and prevents it from flowing in the opposite direction.

Therefore, in the flow-through direction, the ohmmeter needle should swing quickly to the first one-third of the scale but not to zero which would mean that the diode is shorted.

As to the reading, it is enough that the value remains constant for diodes of the same polarity and function.

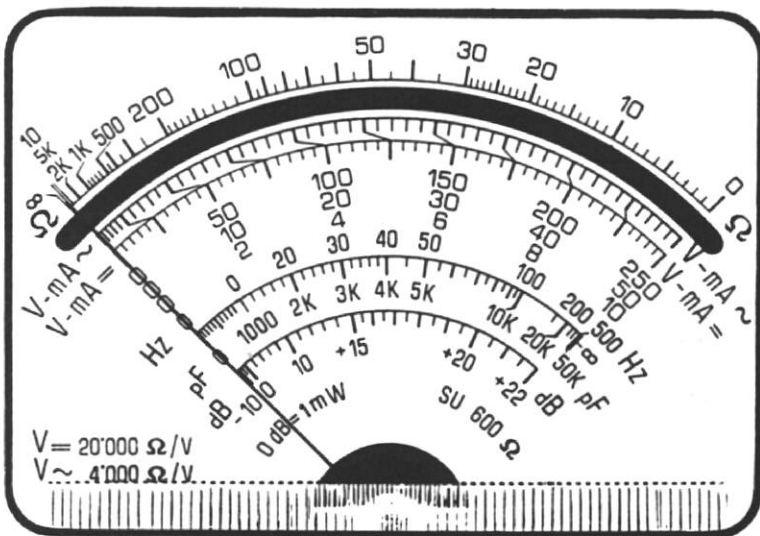

In the no-flow direction the ohmmeter needle should remain stationary at the high (Kilo-Ohm) range of the scale.

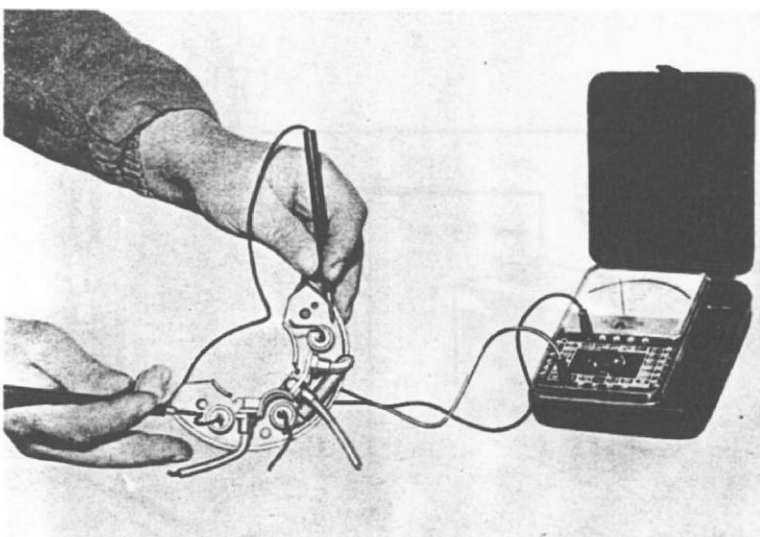

TESTING A POSITIVE DIODE WITH AN OHMMETER.

Placing the prods as shown the diode allows the current to pass through; therefore the needle will swing down the scale. Reversing the prods the current flow is blocked and the needle will remain stationary.

As to the ohm reading, refer to the note above.

TESTING DIODES WITH AN OHMMETER

TESTING A NEGATIVE DIODE WITH AN OHMMETER

Proceed the same way as for positive diodes keeping in mind that the polarity is reversed.

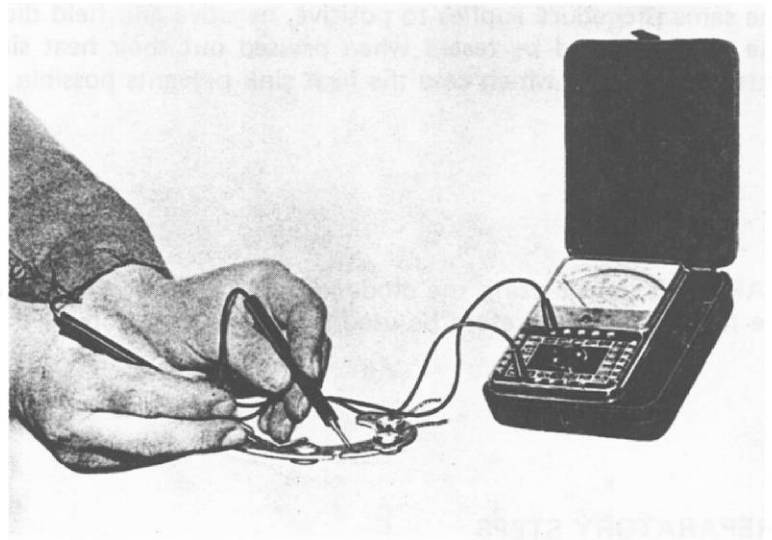

TESTING A FIELD DIODE WITH AN OHMMETER

Proceed the same way as for a positive diode.

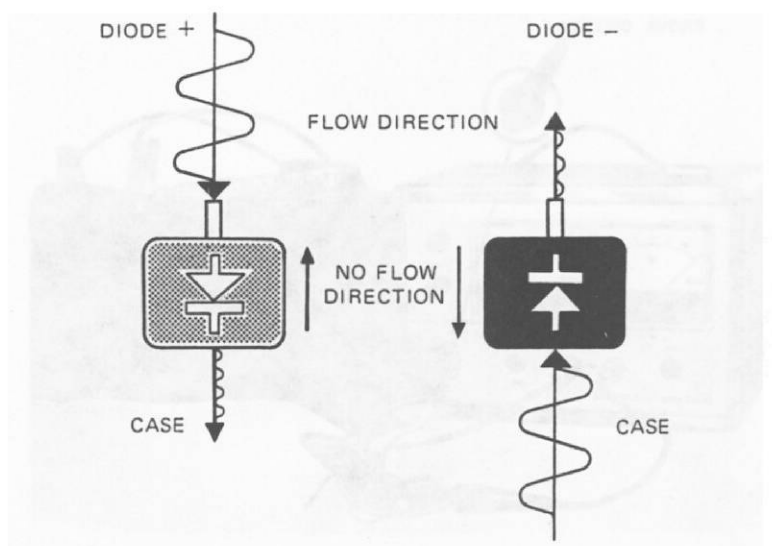
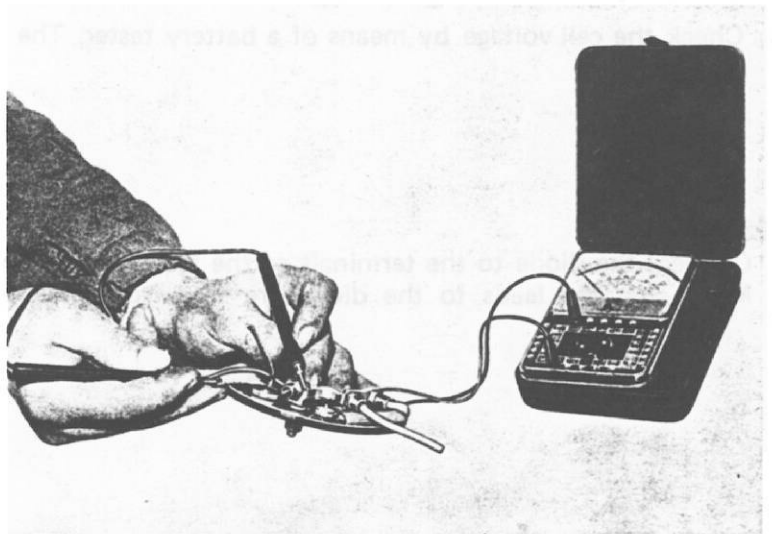

ALTERNATOR

TESTING DIODES WITH A SPECIAL DIODE TESTER

The same procedure applies to positive, negative and field diodes as well. The diodes should be tested when pressed out their heat sink; however, they can be more practically tested as fitted in which case the heat sink prevents possible overheating.

WARNING: when using the diode tester, keep in mind that there are dangerous points under voltage in it; the tester should therefore be used by skilled operators.

PREPARATORY STEPS

- Connect the tester to an A.C. supply after having made adjustments for the voltage.
- Connect a 2-volt battery to the suitable socket in the back of the tester or have it connected to one cell of a common storage battery.
- Check the cell voltage by means of a battery tester. The voltage must not exceed 2 volts.

TEST

- Connect the diode to the terminals of the tester marked with the diode symbol. Make sure the leads to the diode are free from interference or chance contacts.

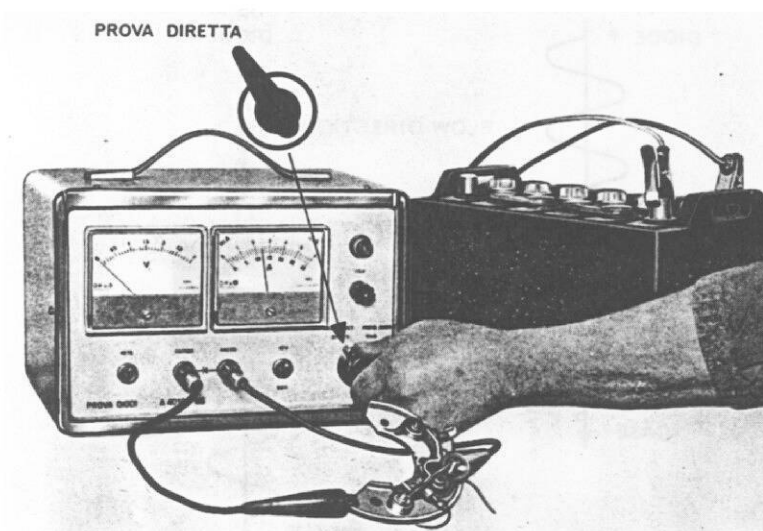

“DIRECT POLARITY” TEST

- Turn the polarity switch to the “direct” position and keep it there a few moments.

The knob rotates against the action of a spring which returns the knob quickly to reduce to a minimum the exposure to current load.

During this test there should be:

- A current reading of 10 to 15 amps. with a battery voltage of 2 volts
- A voltage drop of 1.2 to 1.5 volts.

TESTING DIODES WITH A SPECIAL DIODE TESTER

"REVERSE POLARITY" TEST

- Turn the polarity switch to the "reverse" position and keep it there a few moments. Ammeter and voltmeter needles should remain stationary.

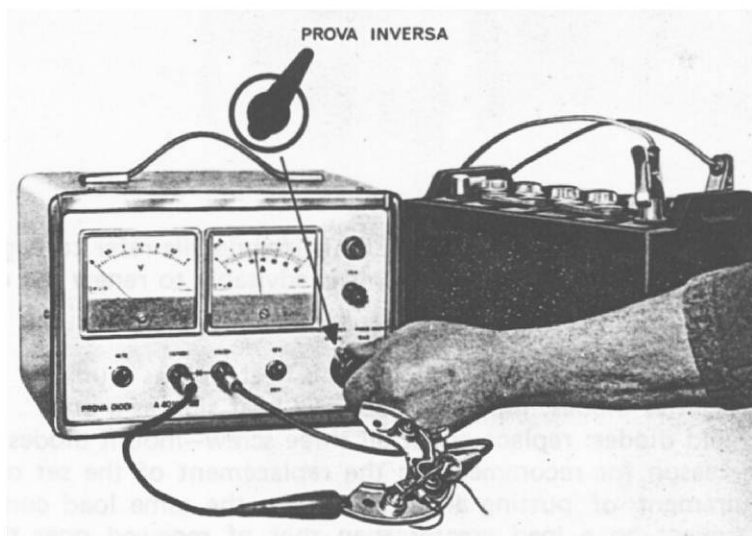

"REVERSE POLARITY" TEST OF A FIELD DIODE

- Proceed the same way as above.

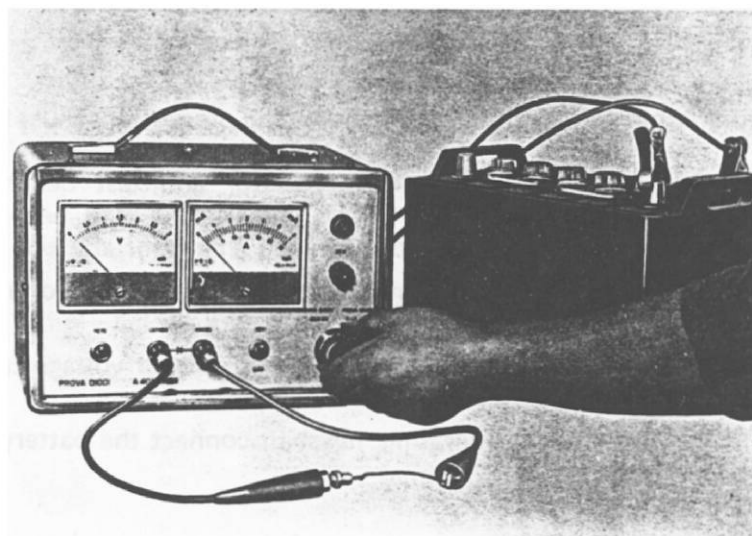

REVERSAL OF POLARITY

In the event the polarity of the diode under test is reversed, in the "direct polarity" test the voltmeter will indicate the battery voltage while in the "reverse polarity" test the needle will swing all the way up scale.

HOW TO DETECT OPEN OR SHORTED DIODES

- A shorted diode can be detected by the voltmeter indicating, in a "direct polarity" test, only the drop in voltage (fractions of a volt) due to the lead resistance. In such a condition the ammeter will indicate the battery shorted cell current whose reading may well exceed 30 amps thus affecting the tester fuse suitably provided to manage these emergencies.
- A shorted diode can be detected, in a "reverse polarity" test, by the ammeter needle swinging all the way up scale while the voltmeter shows no reading.
- An open diode can be detected, in a "direct polarity" test, by the voltmeter indicating the battery voltage while the ammeter shows no reading.
- With an open diode in a "reverse polarity" test both dials show no reading.

TESTING ON BENCH

REPLACING DIODES – GENERAL (for details refer to page 20)

When diodes need replacement, it is advisable to renew the complete set of three instead of single diodes, i.e.:

- Positive diodes: replace diodes and heat sink as a unit.
- Negative diodes: replace diodes and heat sink as a unit.
- Field diodes: replace either all three screw-mount diodes or the diodes and bracket assembly.

The reason for recommending the replacement of the set of three diodes instead of single diodes is the requirement of putting all diodes under the same load conditions, being patent that worn diodes would be subject to a load greater than that of renewed ones thus leading to operating conditions in which faults are more likely to occur.

TESTING THE ALTERNATOR ON BENCH

Before commencing the tests the following precautions must be taken:

The leads connecting alternator, regulator and test bench must be tightened firmly. No provisional connections should be made or, in the event a lead becomes accidentally disconnected during testing, excessive voltage will be developed in the alternator and the diodes destroyed.

To test diodes, only direct current up to a maximum voltage of 24 volts can be applied. Higher voltages would irretrievably ruin the diodes.

Tests for grounds or shorts of windings with higher voltage can only be performed when diodes have been disconnected.

When the alternator is operating, never disconnect the battery cable or the diodes will be damaged.

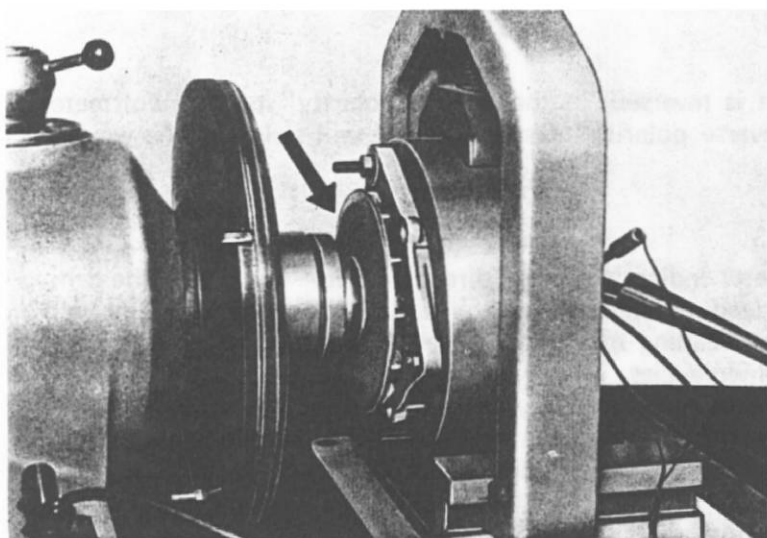

The alternator must be installed on the test bench together with its fan. If the fan has been removed for inspection, it must be reassembled before testing the alternator. However, the pulley must not be fitted. Some alternators have fan and pulley riveted together. This type of alternator cannot be installed on the test bench. To do so, replace the fan in unit with the pulley with a fan of the key type bearing the P.N. 106.00.05.521.00.

TESTING ON BENCH

INSTALLING ALTERNATOR AND REGULATOR ON TEST BENCH

- Install the alternator and the regulator on test bench.
- The alternator must be secured on the test bench by means of the special fixture A.1.0008.
- Take the precautions as outlined on page 14.
- Connect the alternator terminal B+ to the battery.
- For pre-excitation a test lamp of at least 2 watts must be connected across terminals B+ and D+/61.
- When the battery is switched on, the lamp should light up.

TEST WITH REGULATOR

- When the alternator runs:
 - at 800 rpm the lamp must go off.
 - at 900 rpm the voltmeter and the ammeter start indicating.
 - increasing further the RPM, the voltmeter needle should settle at 14 volts.
 If the voltmeter needle indicates less or more than 14 volts, replace the regulator with a new one.
 - the ammeter needle will in turn indicate from 10 to 15 amperes according to the battery; on continuing the tests the ammeter reading will go down to 5-6 amps.

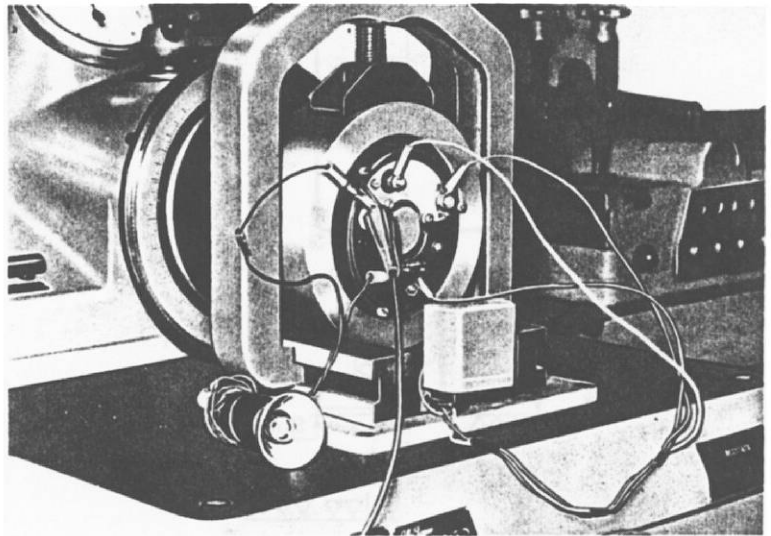

TEST WITHOUT REGULATOR

- Take the regulator away and fit in its place a rheostat across terminals D+/61 and DF.
- Such a hook up allows to weaken the excitation so as not to exceed 14 volts. The rheostat should be operated carefully and smoothly by its manual control (X on the bench shown). The rheostat must have a resistance of at least 100 ohms (3 amp. current). The alternator is delivering rated output when such readings as 14 volts on the voltmeter and 30 amps on the ammeter can be maintained simultaneously.

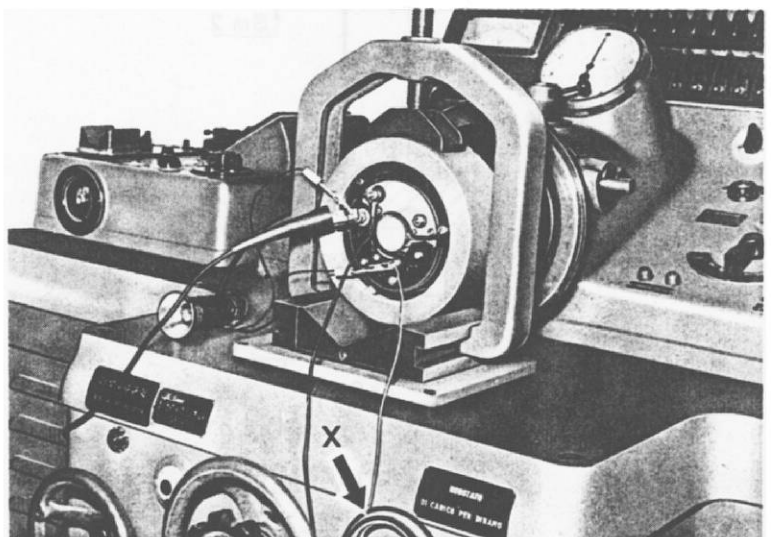

SPECIAL TOOLS FOR REPLACING DIODES

WARNING. The replacement of single diodes is not recommended unless strictly necessary (refer to page 14).

However, if a diode needs replacement, use the following special tools to be ordered to ALFA ROMEO or locally manufactured according to the drawings shown.

Material: C20 UNI 5332-64

Brinell Hd: $30D^2 \approx 150 \text{ kg/mm}^2$

DIMENSIONS IN MILLIMETRES

Surface ∇ = 500 microinches
 Roughness: AA-CLA
 $\nabla\nabla$ = 125 microinches
 AA-CLA
 $\nabla\nabla\nabla$ = 32 microinches
 AA-CLA

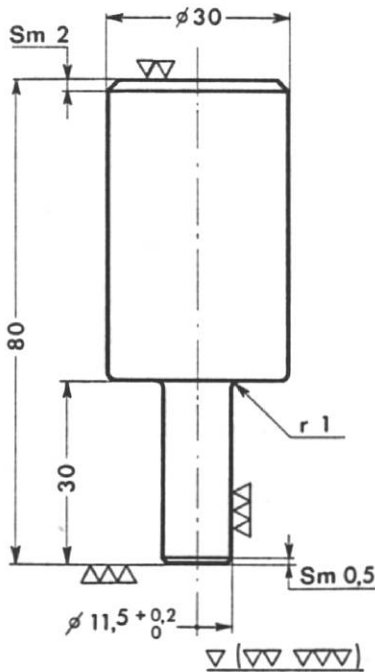

Tool for pulling diodes: A.3.0248

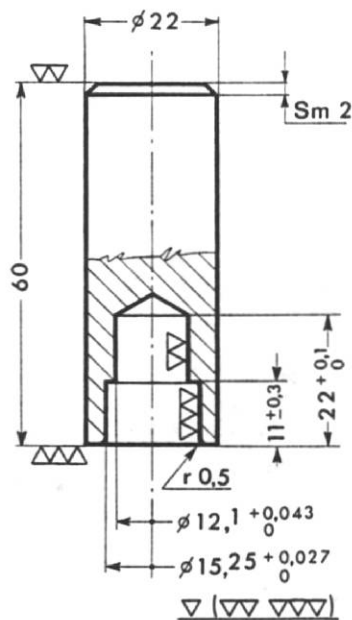

Tool for trueing the mounting boss of diodes: A.4.0122

SPECIAL TOOLS FOR REPLACING DIODES

Tool for driving diodes: A.3.0249

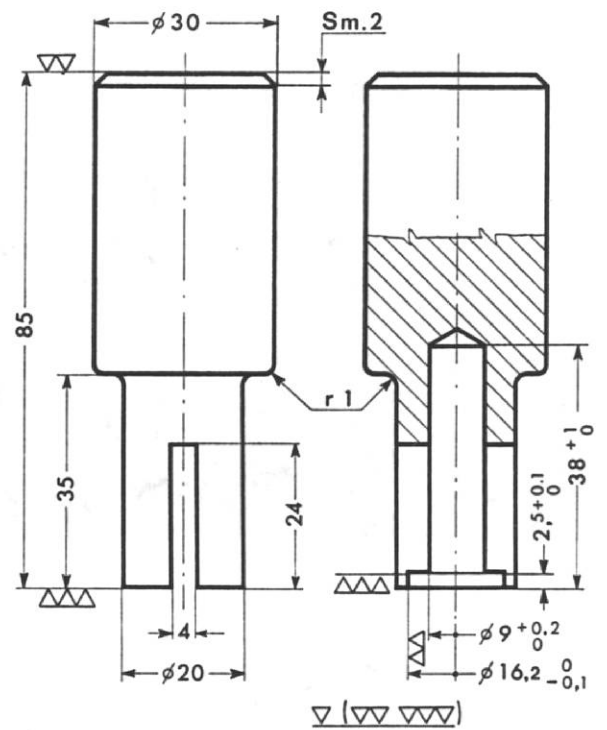

Tool for trueing diode mounting boss hole: A.4.0123

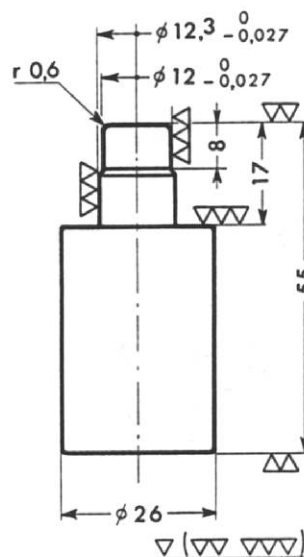

Support tool for pulling and driving diodes: A.3.0250.

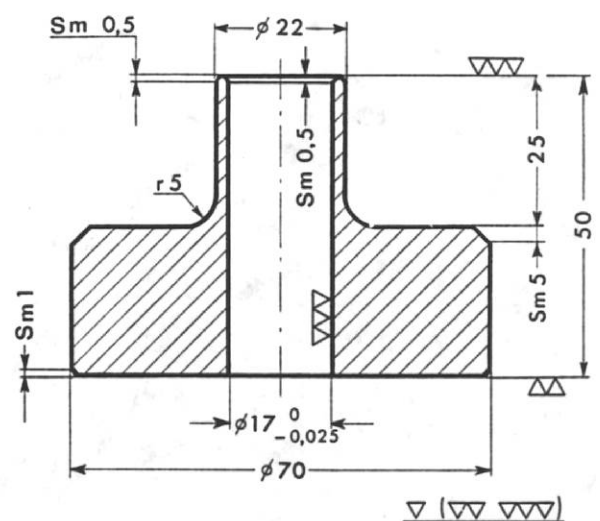

DISASSEMBLY

PULLEY - BRUSH HOLDER - END FRAME

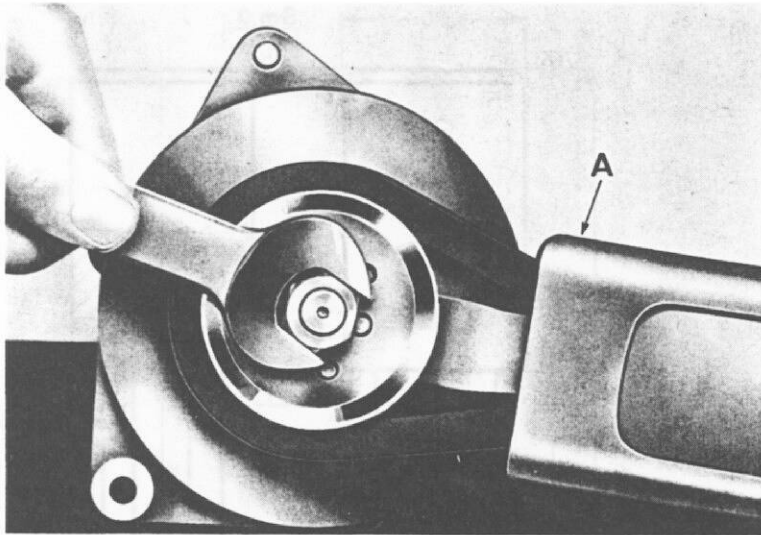

If no definite trouble is detected during the preceding tests, the alternator should be disassembled and thoroughly inspected as outlined on the following pages.

DISASSEMBLING THE ALTERNATOR
Hold the drive belt with a suitable tool (A) and unscrew the nut with a 22 mm wrench. Remove the drive pulley.

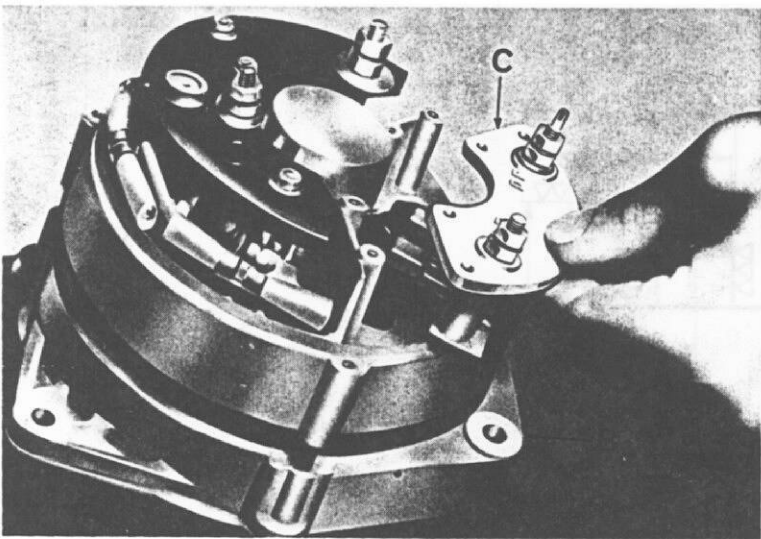

Mark the position of drive end frame (B) with respect to the other components. Loosen the screws attaching the brush holder (C), take away the screws and remove brush holder and brushes as a unit.

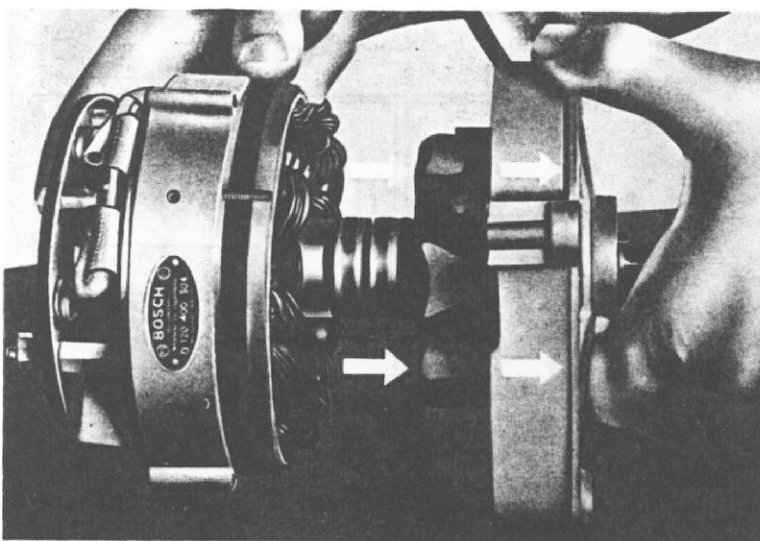

Loosen the drive end frame attaching screws and carefully withdraw the rotor and end frame as a unit from the stator.

ROTOR - BALL BEARING

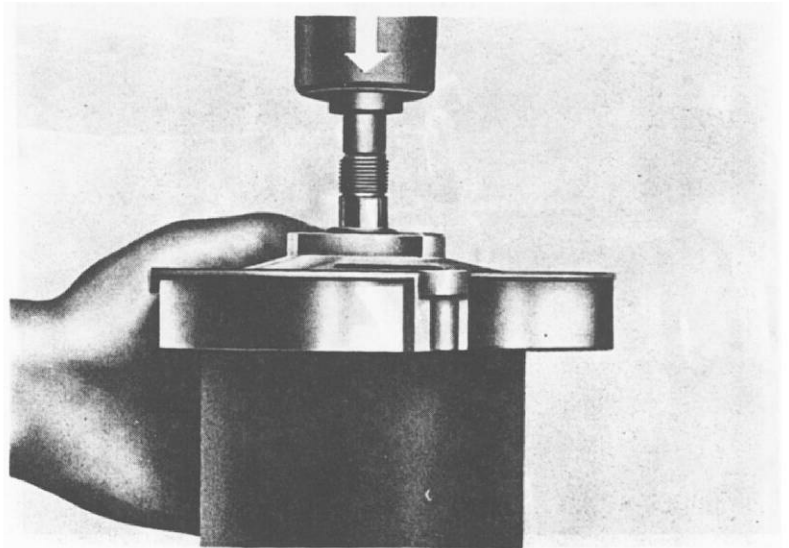

Pull the rotor apart from end cover with a suitable press and a support as shown. While doing this, keep the rotor stationary.

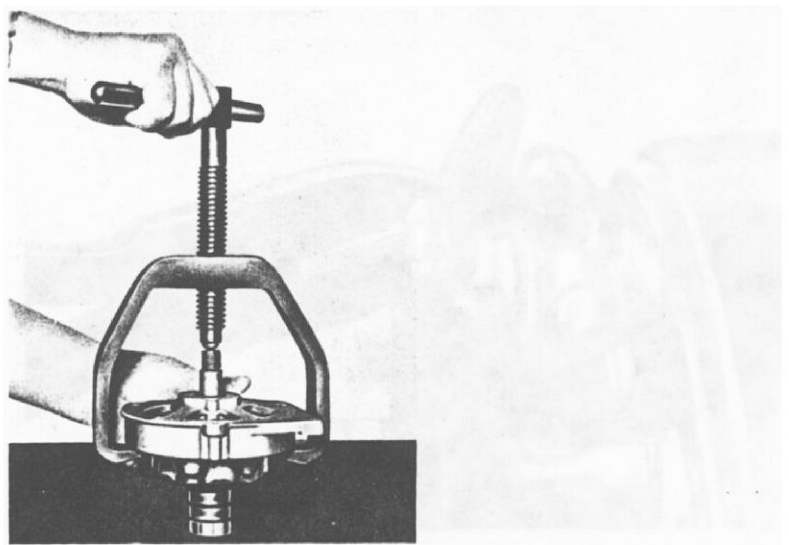

The rotor can also be withdrawn from the end frame by using a puller or the special tool A.3.0109. In case the special tool is used, screw the pulley attaching nut on the shaft threaded shank by about two threads to provide a wider thrust surface.

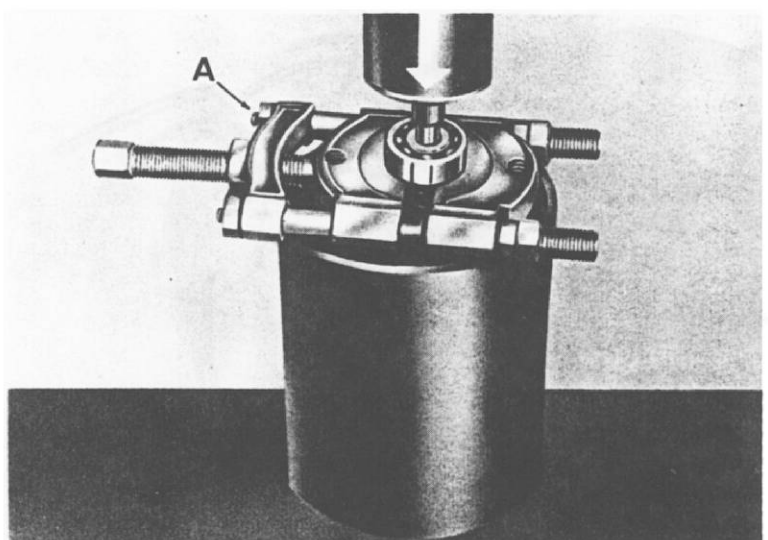

Remove the bearing from the slip ring side by means of a suitable clamp (A) and a press, or with a puller. Pressure should be applied to the inner race. If damaged on removal, replace the bearing with a new one.

REPLACING DIODES

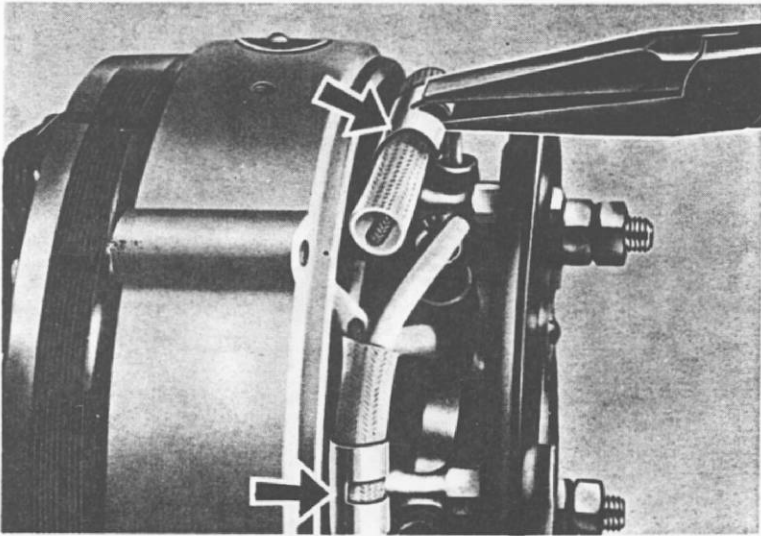

With suitable pliers free the leads to diodes and stator from the clips. Spread apart the leads so that they can then be easily disconnected.

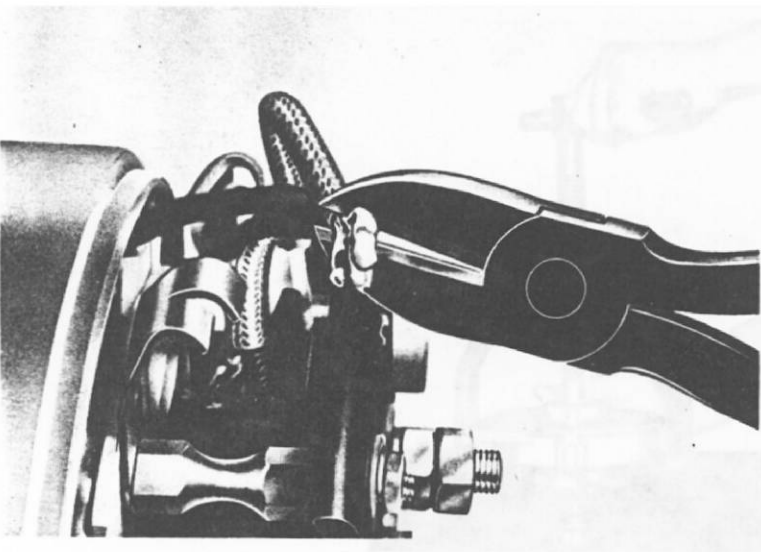

Disconnect the leads by unsoldering or cutting them as shown. Slip out and retain the insulating sheaths.

Before further disassembly, test diodes according to one of test procedure as applicable (refer to page 9 et seq.).

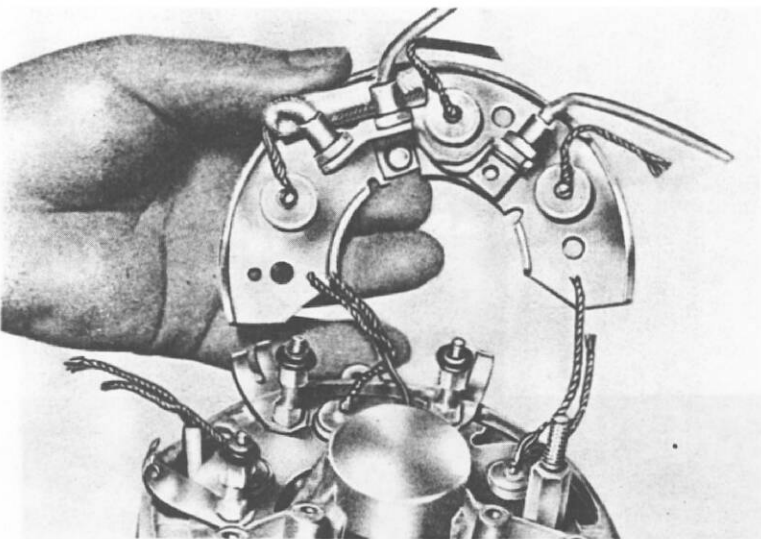

As recommended on page 14, replace the complete set of:

- three positive diodes
- three negative diodes
- three field diodes

Positive Diodes:

remove the positive diode heat sink. When disassembling, special care should be given to the insulating washers.

REPLACING DIODES

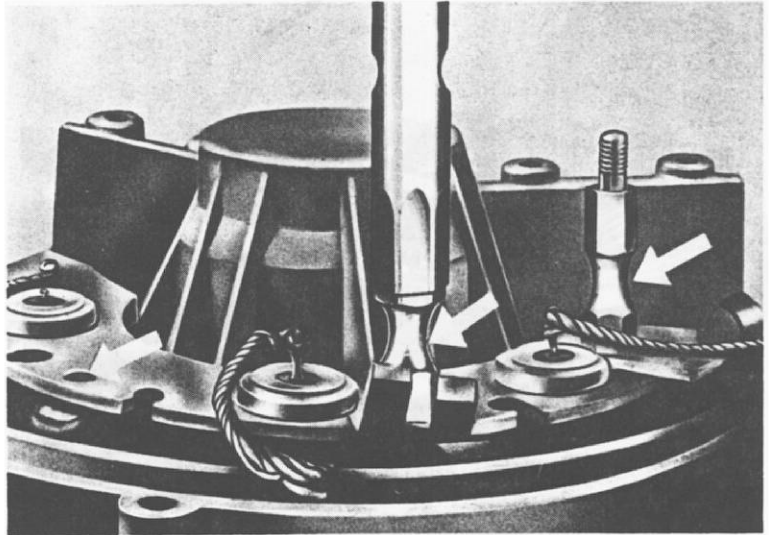

Negative diodes:
take the negative diode heat sink away
with a box spanner.

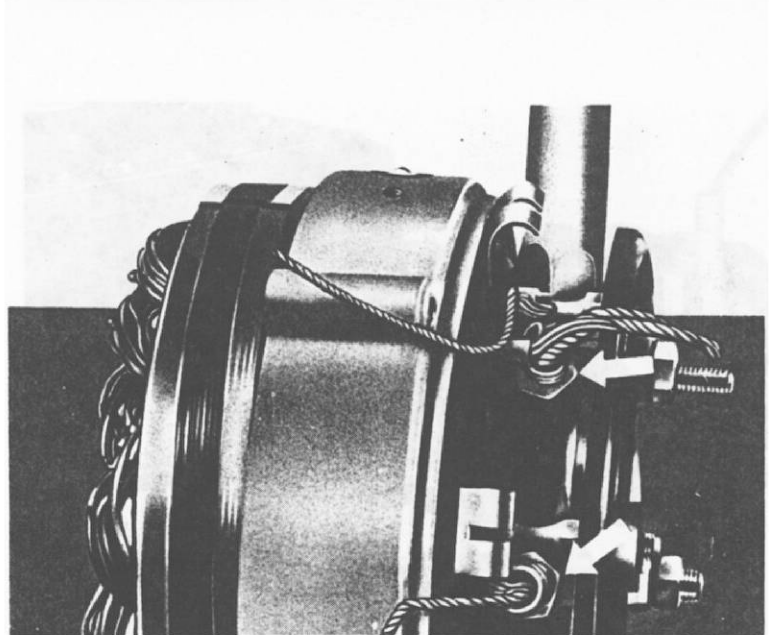

Field diodes:
In the event of screw-mount diodes:
unscrew them with a suitable wrench.
Handle the wrench so that it works flat in
the plane of diode hex head.

In case of field diodes in unit with their bracket: Replace the set of three diodes complete with bracket.

CLEANING

For a thorough cleaning of the alternator component parts, petrol or trichloroethylene is recommended; however, use them sparingly.

OVERHAUL

INSPECTION AND TESTING

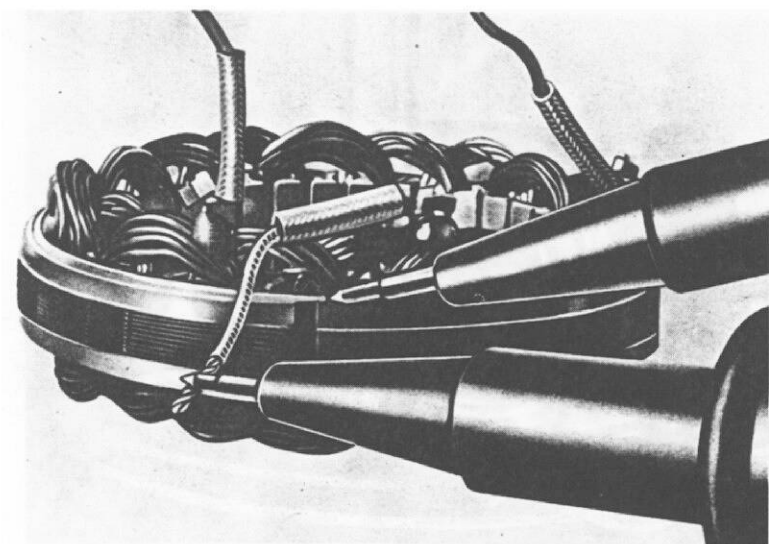

Check the stator windings for grounds with points.
Test voltage:

40 volts A.C.

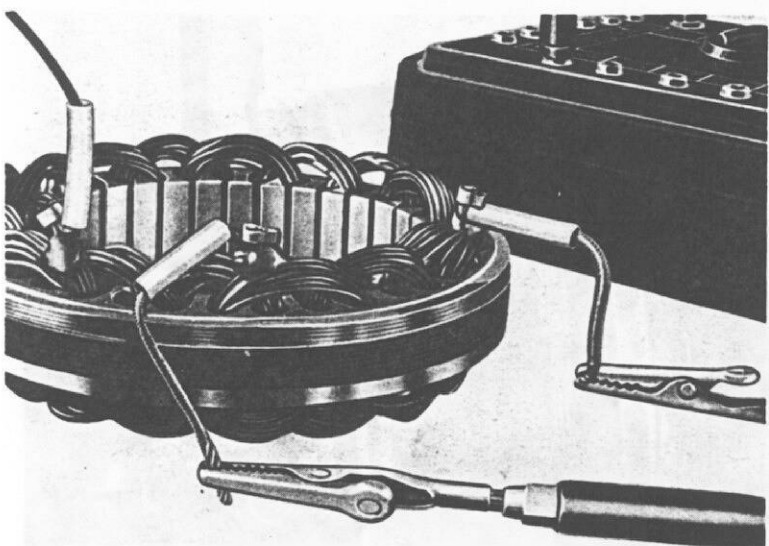

The resistance of each phase winding across output wires should be:
0.26 Ohm + 10%
Check windings for shorts and opens.

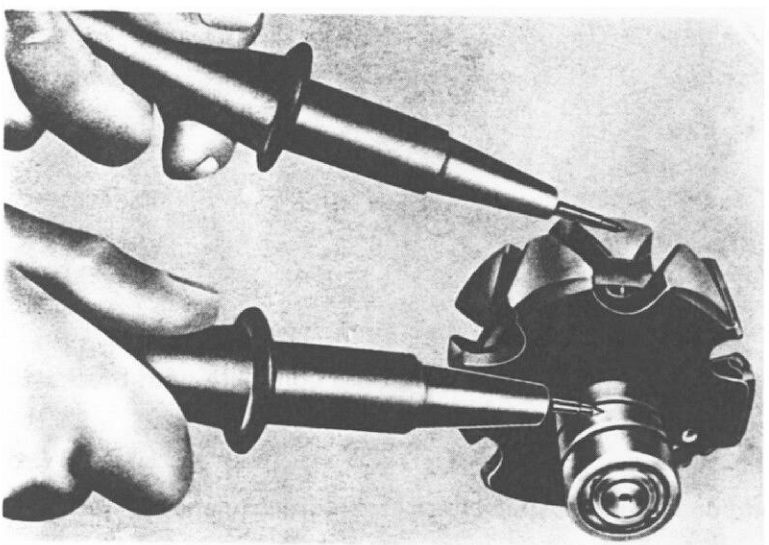

Check rotor poles for grounds with points.
Test voltage:

40 volts A.C.

INSPECTION AND TESTING

Check the field winding for shorts and opens.

The resistance should be:

4.0 Ohm + 10%

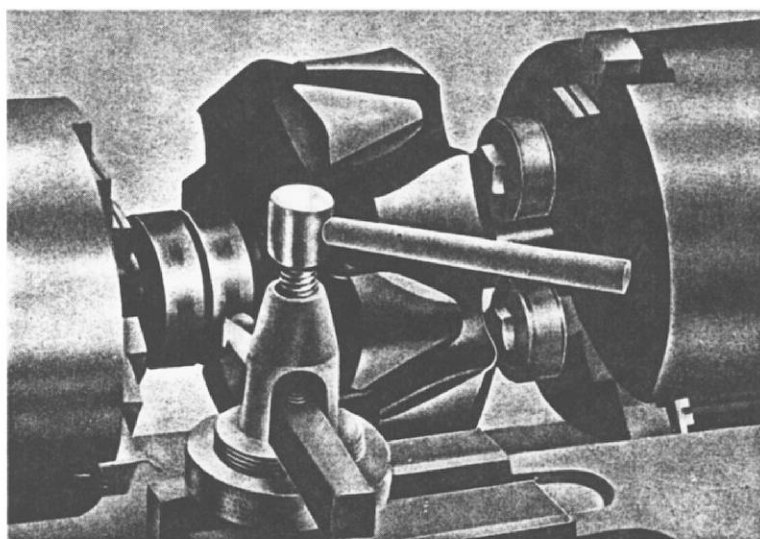
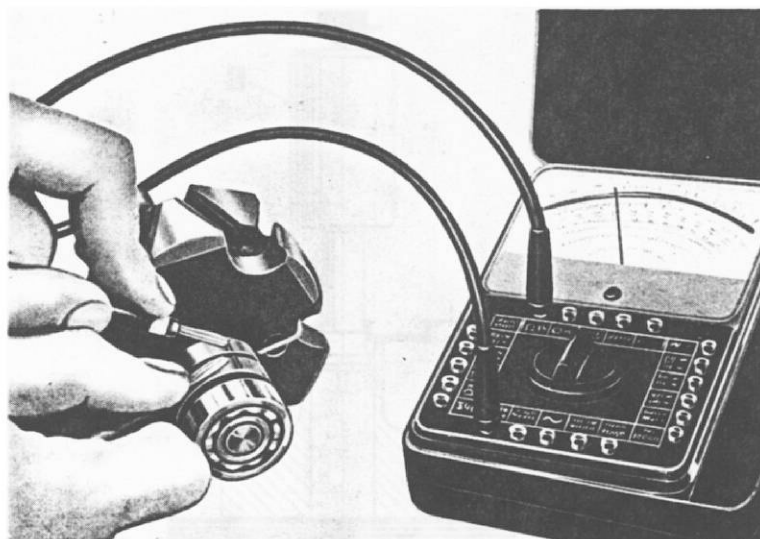

Turn the slip rings in a lathe.

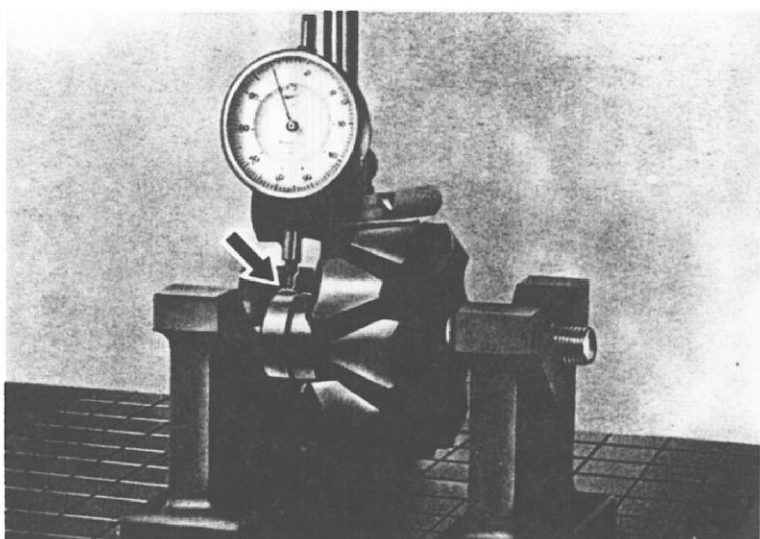

After the slip rings have been turned in a lathe, check them for run out.

Maximum permissible out-of-round: 0.03 mm.

Minimum slip ring O.D.: 31.5 mm.

Rotor maximum out-of-round: 0.05 mm.

REPLACING ONE POSITIVE OR NEGATIVE DIODE

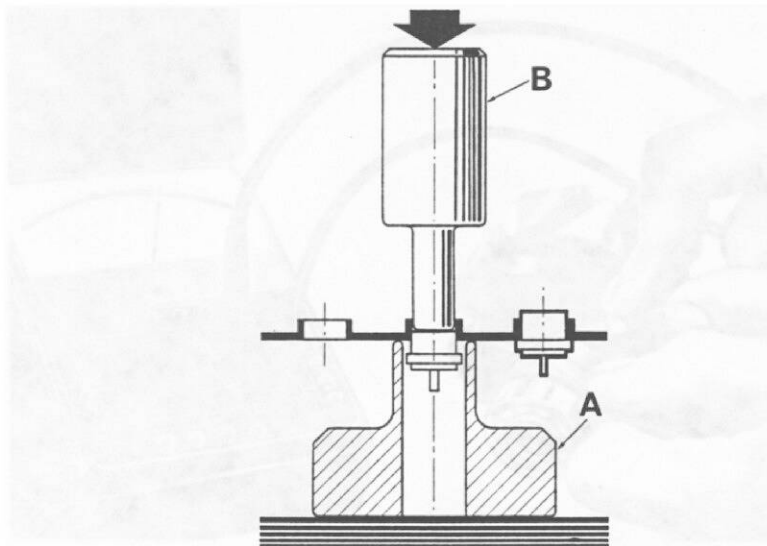

WARNING. Changing single diodes is not recommended (Refer to page 14). However, if such a need arises, follow the directions given below.

PULLING

- Place the heat sink on the special tool A (A.3.0250) and press out the diode with tool B (A.3.0248).

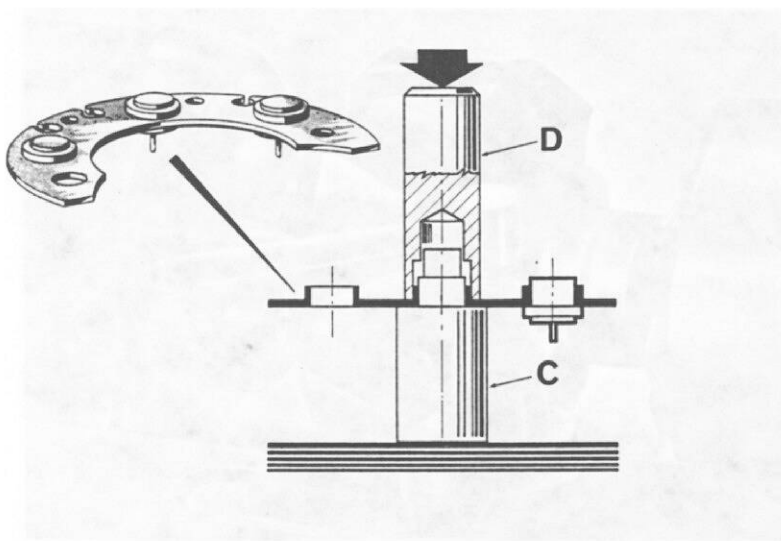

TRUEING THE MOUNTING BOSS

Before pressing in a new diode true the hole in the mounting boss as follows:

- Place the heat sink on special tool C (A.4.0123);
- True the boss with special tool D (A.4.0122).

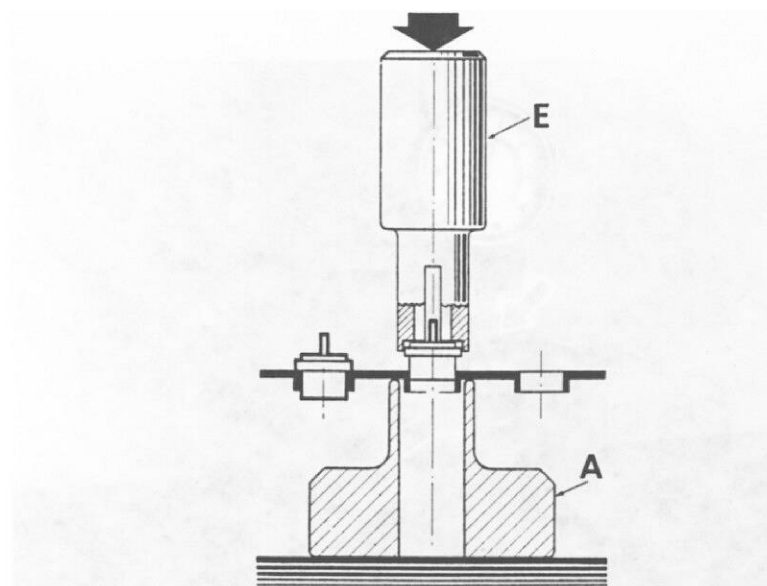

DRIVING

- Lubricate the hole in mounting boss with Bosch 0l 63 v2 oil.
- Place the heat sink on special tool A (A.3.0250).
- Press fully in the diode with tool E (A.3.0249)

NOTE – It is recommended to use an arbor press to perform all the above work. On completion of the procedure, test diodes for proper operation (refer to page 9 et seq.).

DRIVE END FRAME

DRIVE END FRAME

Check the bearing for wear and change it, if necessary.

Usually, this bearing has an operating life of about 60,000 mi. and after that period it should be replaced with a new one.

Pack the bearing with Bosch Ft 1 v 33 grease; fit it in the frame with the close side down as shown. Secure the retainer with the screws.

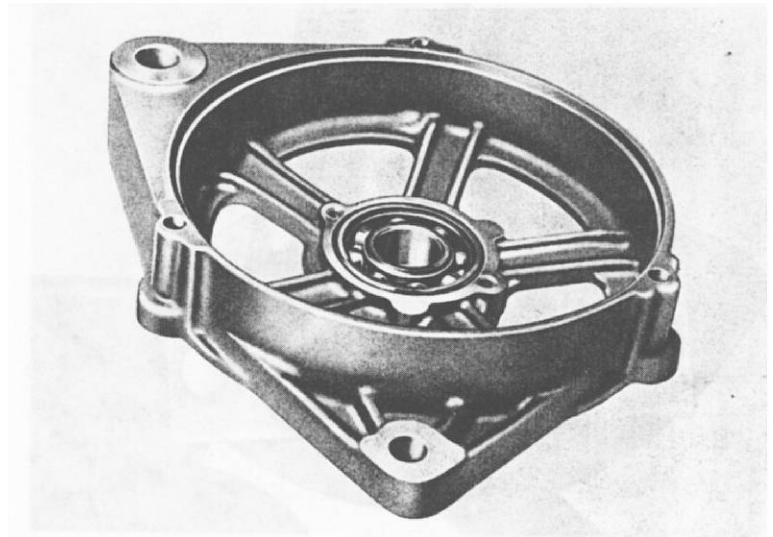

Press the bearing (slip ring side) on rotor shaft. To do so, rest the rotor on a suitable support.

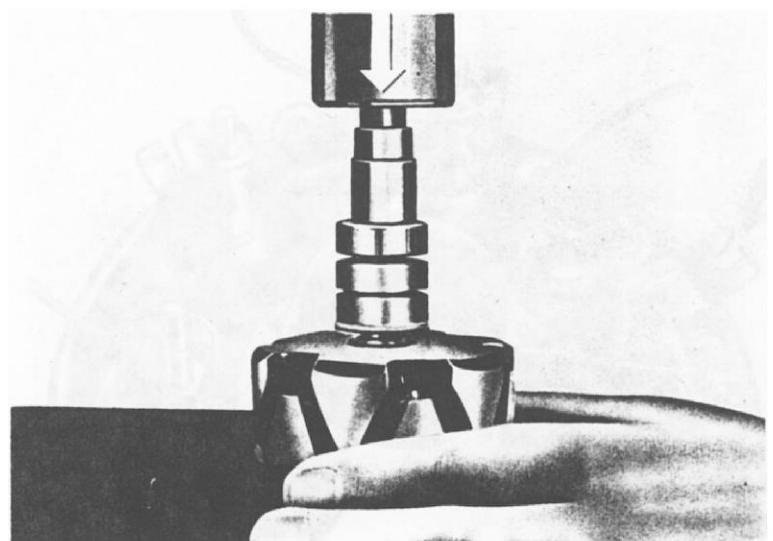

Press the drive end frame on rotor shaft. Make sure the resting surface is clean to prevent foreign matter from entering the bearing.

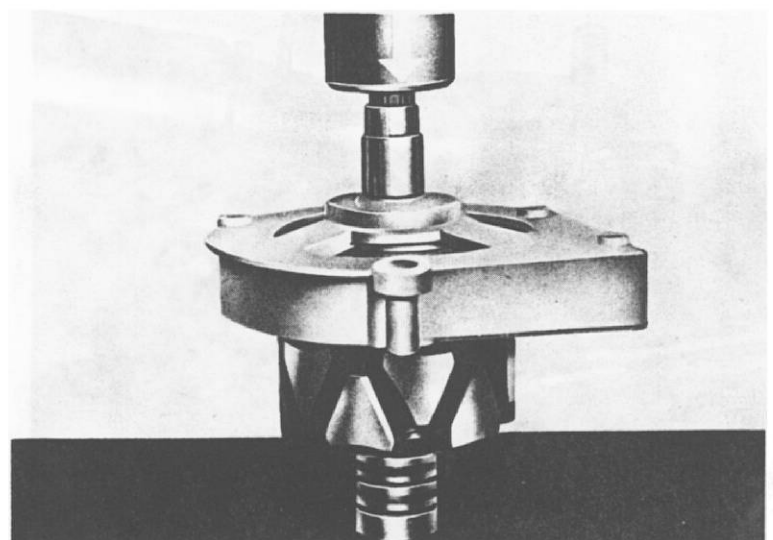

BRUSH - NEGATIVE DIODE HEAT SINK

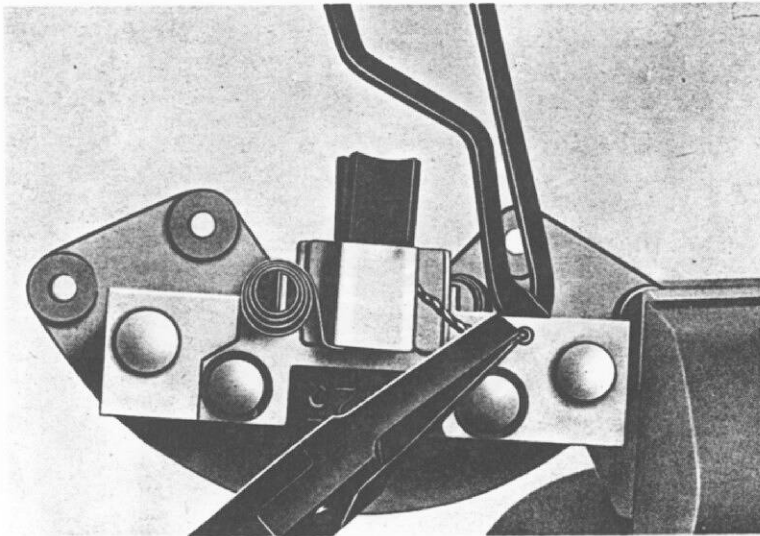

CAUTION:

While replacing the carbon brushes care should be taken to prevent the solder (tin with rosin flux only) from creeping along the copper wire.

Minimum length of carbon brushes: 14 mm.

After fitting, check brushes for binding.

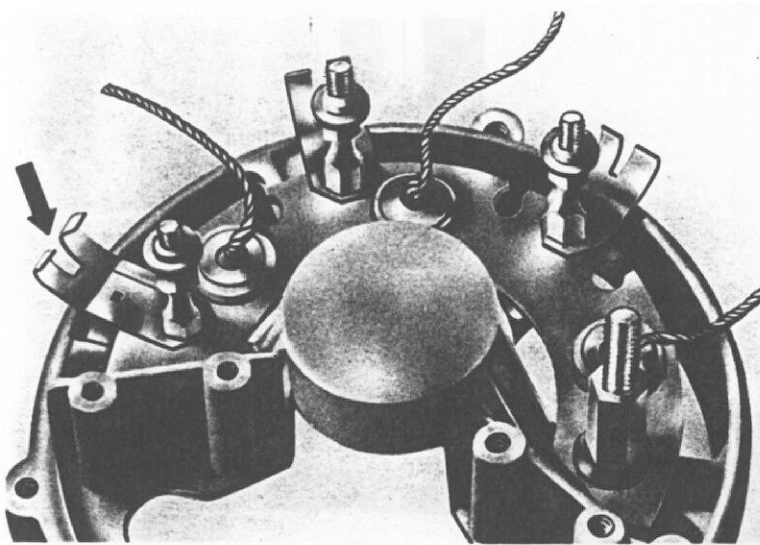

Fit the negative diode heat sink and the wire clips. Screw in the spacers so that the shorter threaded shank is outward. The longest clip must be fitted at the left side as shown. Properly fit the insulating washers.

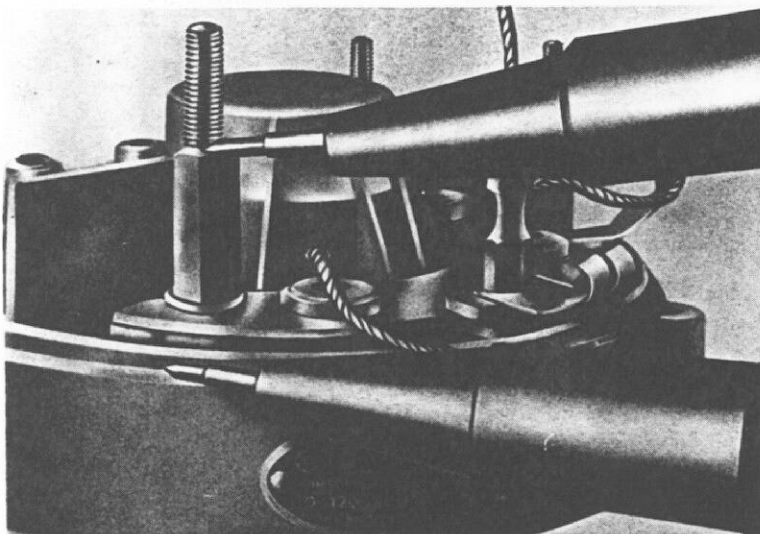

Check terminal B+ for grounds.

Test voltage:

40 volts A.C.

POSITIVE DIODE HEAT SINK

Install the positive diode heat sink, the insulating washers and the lockwashers. On the spacer next to the terminal D+/61, the special dished insulator instead of flat insulating washers must be fitted. Tighten the nuts with a box wrench.

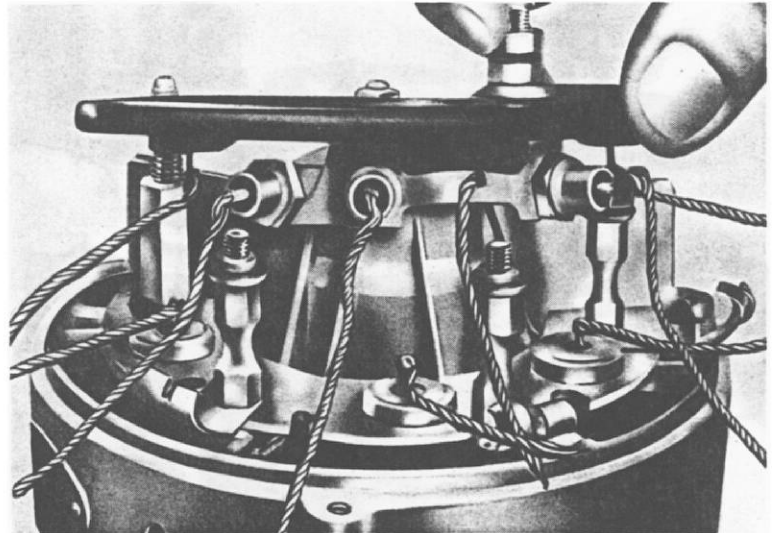

Fit the stator to the slip ring end frame. Bring together the positive and negative diode wires and slip on them the sheath. Also put sheaths over the field diode wires and stator winding leads. Tape provisionally together the four leads. Mount and solder in place the metal ring. Take care that solder does not run down the wires for more than 4 mm.

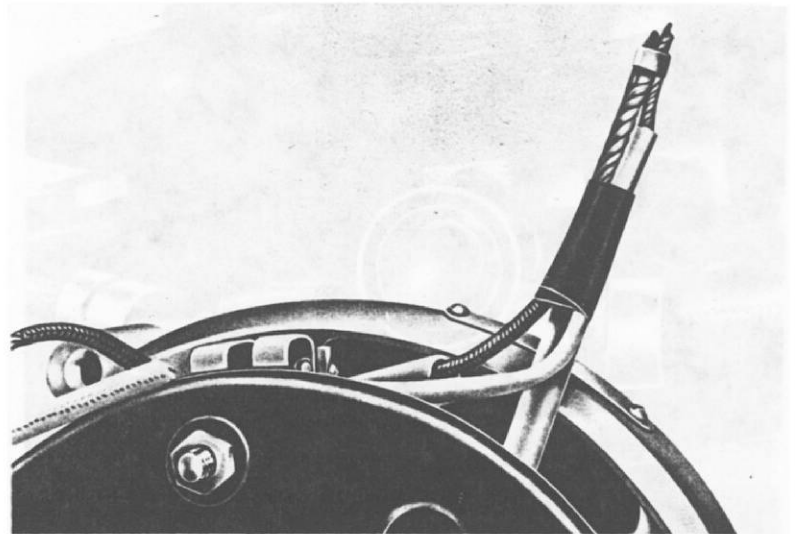

After soldering cut the ends of wires projecting beyond the metal ring. Remove the tape. Install the outer sheath.

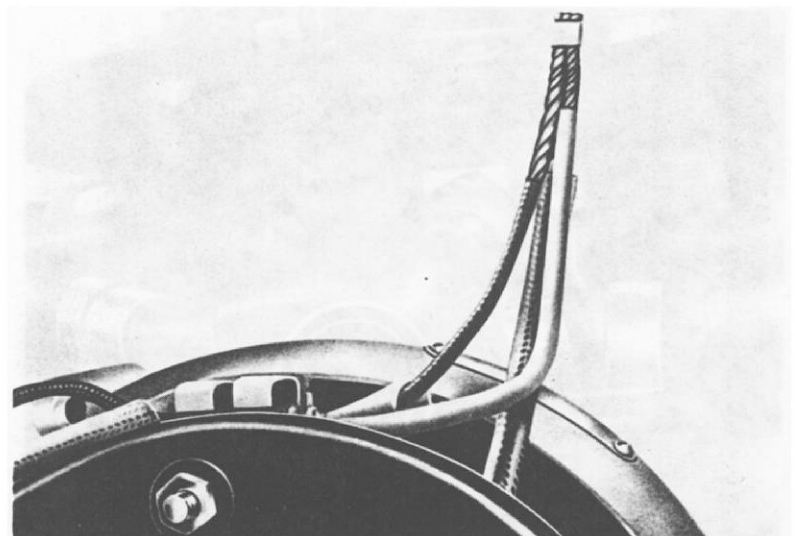

REASSEMBLY
CONNECTIONS

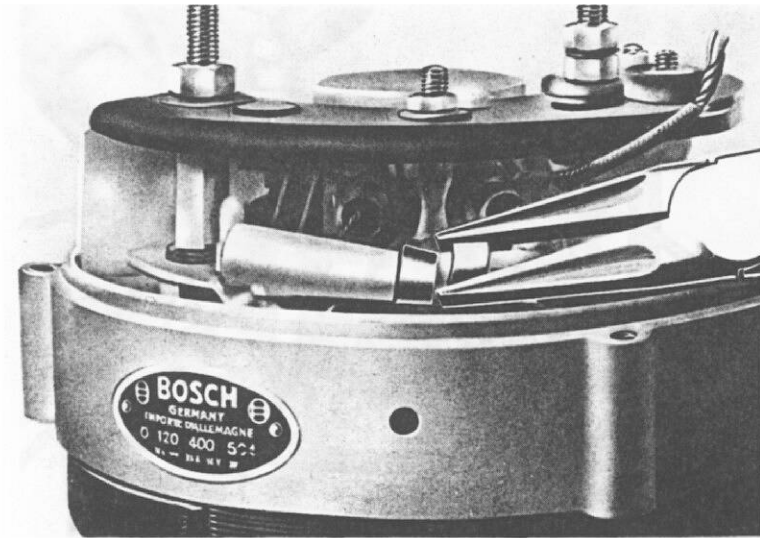

Bend the clip tabs properly with pliers.

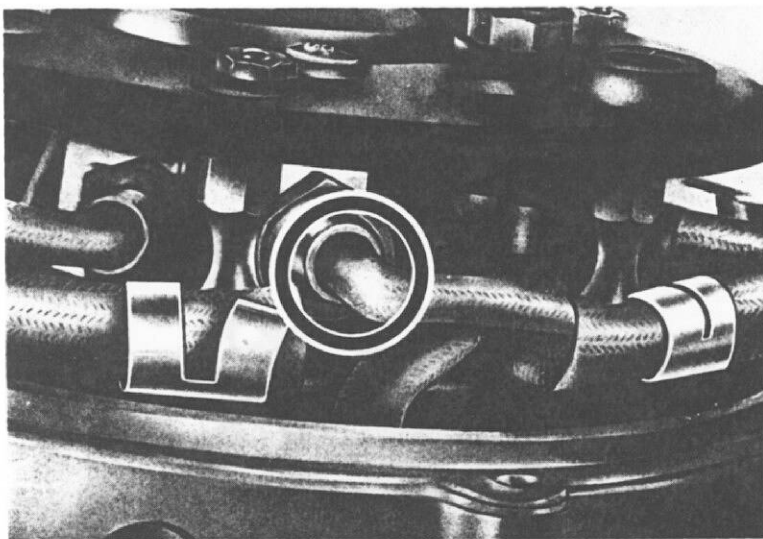

Position the sheath so that the field diode lead is fully protected as shown.

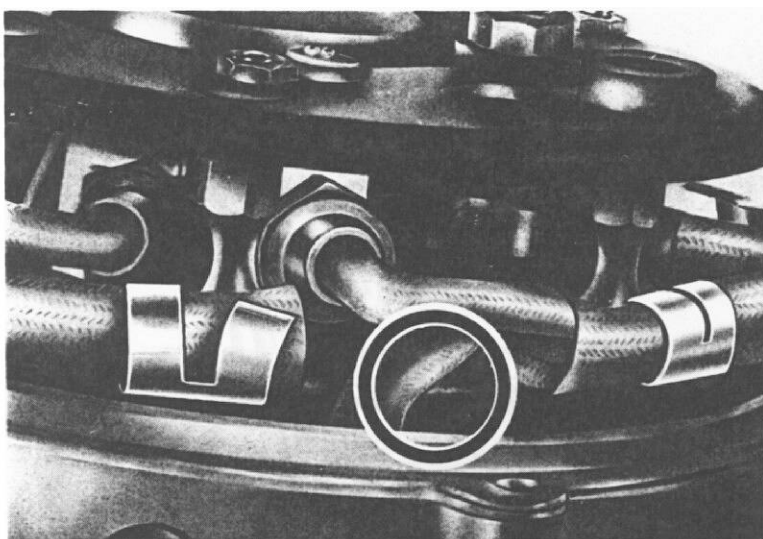

The stator winding output leads should be so positioned as to stand astride of negative diode heat sink as shown.

ROTOR - BRUSH HOLDER

Make sure the leads are firmly secured with the clips. It is essential that the leads are fastened in the clips in such a way that an air gap of at least 1/8" (3mm) exists between the leads and the frame; the insulating sheaths should project of at least 1/8" over the solderings.

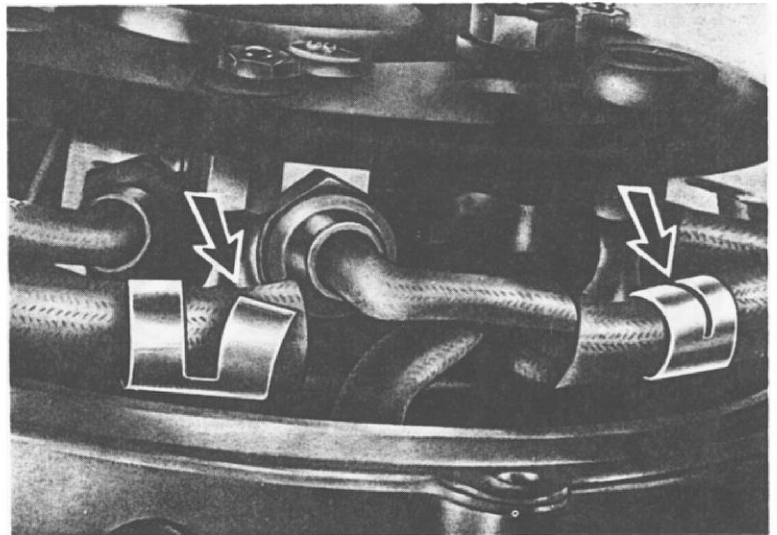

Install the rotor frame assembly according to the reference marks made on disassembly. Fit the brush holder, install the pulley and the fan and tighten the securing nut to: 25.3-28.9 lb. ft. (3.5-4 kgm). After reassembling, protect the positive diodes previously replaced with Bosch FI 87 v 1 compound.

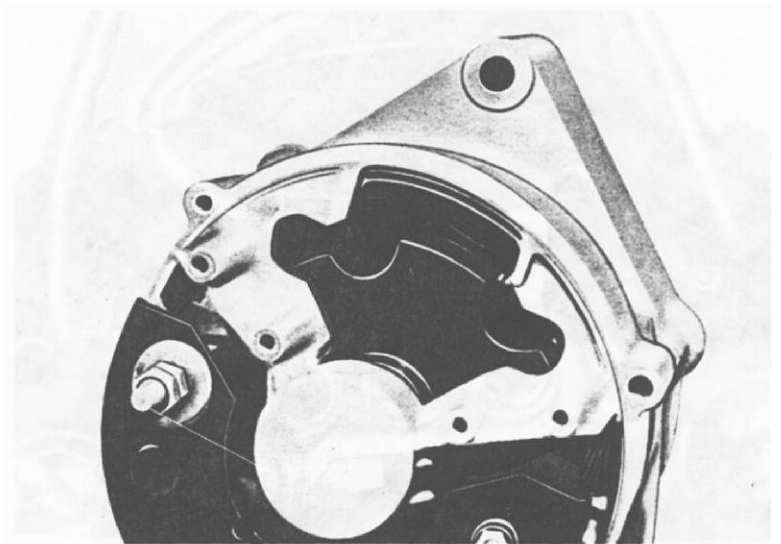

REASSEMBLY PROCEDURE FOR ALTERNATORS WITH
PRESS-FIT INSTEAD OF SCREW-MOUNT FIELD DIODES

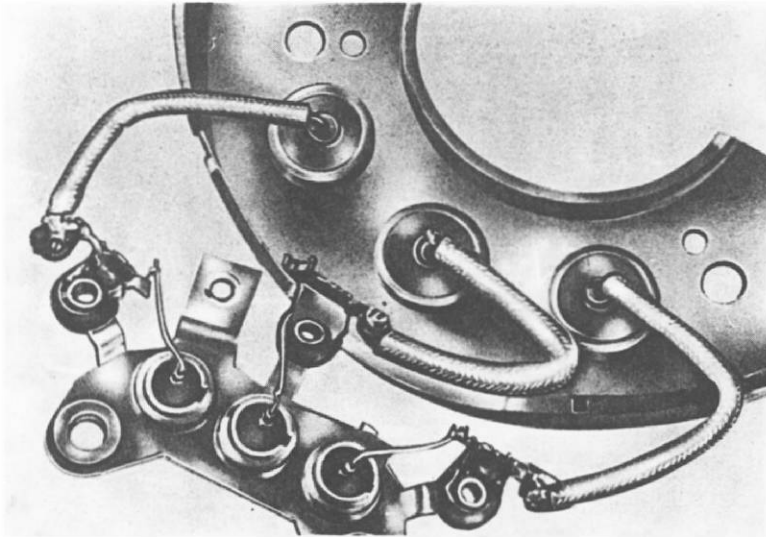

Before fitting the field diode bracket, solder the three positive diode wires to the field diode bracket itself.

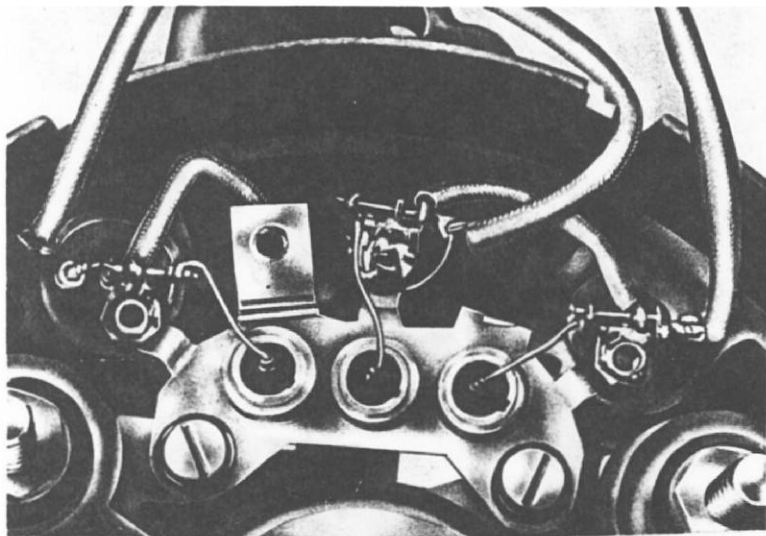

After the field diode bracket has been fitted, connect by soldering the stator, negative diode and field diode leads. When soldering, great care should be taken to avoid overheating the diodes.

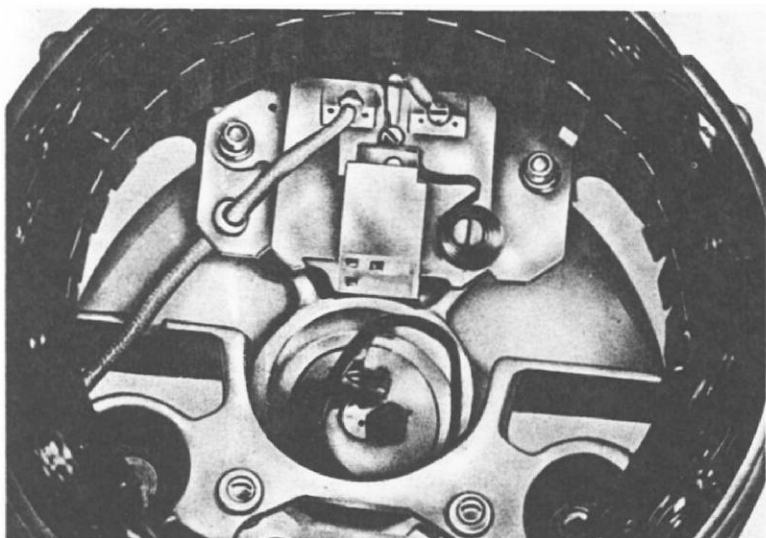

Fit the brush holder. Raise the brushes and keep them up out of way for reassembly. Connect the D+ lead to the field diode bracket. Place the wave washer into bearing seat. Smear the ball bearing seat with Bosch Ft 70 v1 grease. Install the rotor onto the drive end frame by reversing the procedure outlined on page 18. Carefully insert the rotor and end frame assembly in the stator and secure with the three screws. Fit the positive diode heat sink and lock it in place. Fit the brush springs with the aid of a screwdriver or similar tool.

SPECIFICATION

Slip ring out-of-round	max 0.03 mm.
Rotor out-of-round	max 0.05 mm.
Minimum length of carbon brushes	14 mm.
Brush spring pressure	300-400 gr.
Minimum O.D. of slip rings	31.5 mm.
Stator winding resistance	0.26 Ohm + 10%
Field winding resistance	4.0 Ohm + 10%
Tightening torque of drive pulley securing nut	3.5 – 4.0 Kgm
Tightening torque of field diodes	.135 – .175 Kgm
Ball bearing grease (1.5 gr per bearing)	{ Bosch Ft 1v 33 Bosch Ft 70v 1
Diode lube	Bosch OI 63v 2
Insulating compound for positive diode heat sink	Bosch FI 87v 1

Alfa Romeo

Via Gattamelata,,45 - 20149 - MILANO

DIASS - Pubblic. N.1384

9/69 - 3000

Printed in Italy

LITOROLA - MILANO

All rights reserved. This book, or parts thereof,
may not be reproduced in any form without
permission of ALFA ROMEO S.p.A.

